

MDD Digital AC Servo Motors with Liquid Cooling

Project Planning Manual

DOK-MOTOR*-MDD**LIQUID-PRJ1-EN-P



Title MDD Digital AC Servo Motors with Liquid Cooling

Type of documentation Project Planning Manual

Documenttype DOK-MOTOR*-MDD**LIQUID-PRJ1-EN-E1,44 • 10.96

- Internal file reference*
- Mappe 12
 - MDDLI-PJ.pdf
 - 209-0069-4380-00

Reference This electronic document is based on the hardcopy document with document desig.: 209-0069-4380-00 EN/03.95

- Purpose of documentation* This documentation serves to
- clarify technical data
 - mechanically integrate the motor into the machine
 - electrically integrate the motor into the machine
 - outline all available options
 - specify order details for the motor and connecting accessories

Change procedures

Designation of documentation up to present edition	Release-date	Comments
209-0069-4380-00 EN/03.95	Mär./95	First Edition
DOK-MOTOR*-MDD**LIQUID-PRJ1-EN-E1,44	Okt./96	Introduction of document type

Copyright © INDRAMAT GmbH, 1995
 Copying this document, and giving it to others and the use or communication of the contents thereof without express authority, are forbidden. Offenders are liable for the payment of damages. All rights are reserved in the event of the grant of a patent or the registration of a utility model or design (DIN 34-1)

The electronic documentation (E-doc) may be copied as often as needed if such are to be used by the consumer for the purpose intended.

Validity All rights are reserved with respect to the contents of this documentation and the availability of the product.

Published by INDRAMAT GmbH • Bgm.-Dr.-Nebel-Straße 2 • D-97816 Lohr
 Telephone 09352/40-0 • Tx 689421 • Fax 09352/40-4885
 Dept. ENA (UW, FS)

Table of Contents

1. Liquid-cooled MDD servo motors	5
2. General technical information	8
2.1. Environmental conditions	8
2.2. Motor feedback	9
2.3. Mechanical features	10
2.4. Electrical features	12
2.5. Torque-speed characteristics curves	14
3. Technical data	16
3.1. MDD 090 (liquid-cooled)	16
3.1.1. MDD 090 motor data	16
3.1.2. MDD 090 torque-speed characteristics curves	19
3.1.3. MDD 090 - shaft load	22
3.1.4. MDD 090 - dimensional data	24
3.1.5. MDD 090 - type codes	26
3.2. MDD 093 (liquid-cooled)	27
3.2.1. MDD 093 - motor data	27
3.2.2. MDD 093 - torque-speed characteristics curves	31
3.2.3. MDD 093 - shaft load	37
3.2.4. MDD 093 - dimensional data	38
3.2.5. MDD 093 - type codes	40
3.3. MDD 112 (liquid-cooled)	41
3.3.1. MDD 112 - motor data	41
3.3.2. Torque-speed characteristics curves for MDD 112	45
3.3.3. MDD 112 - shaft load	51
3.3.4. MDD 112 - dimensional data	52
3.3.5. MDD 112 - type codes	54
3.4. MDD 115 (liquid-cooled)	55
3.4.1. MDD 115 - motor data	55
3.4.2. Torque-speed characteristics curves for MDD 115	59
3.4.3. MDD 115 - shaft load	63
3.4.4. Maßangaben MDD 115	64
3.4.5. MDD 115 - type codes	66

4. Electrical power connections	67
4.1. Terminal diagram.....	67
4.2. Connector to cable allocation.....	68
4.3. Motor power connectors	70
4.4. Motor power cables - technical data	71
4.5. Ready-made motor power cables	72
5. Electrical motor feedback connection	74
5.1. Terminal diagram.....	74
5.2. Feedback connector.....	75
5.3. Feedback cable - technical data	75
5.4. Ready-made feedback cables	76
6. Coolant connections	77
7. Index	79

1. Liquid-cooled MDD servo motors

Liquid-cooled digital AC servo motors are rapid-response servo drives when used with digital intelligent drives. They are especially well-suited for use in tooling, textile, printing and packaging machines, as well as robotics, handling and transfer facilities.

Digital AC servo motors permit highest contouring accuracy with high feedrates, especially for cutting in high speed range.

The AC servo motors

- MDD 093 and
- MDD 115

are used, in particular, for high-dynamic applications.

The AC servo motors

- MDD 090 and
- MDD 112

are especially well-suited for high-precision applications requiring extreme synchronicity.

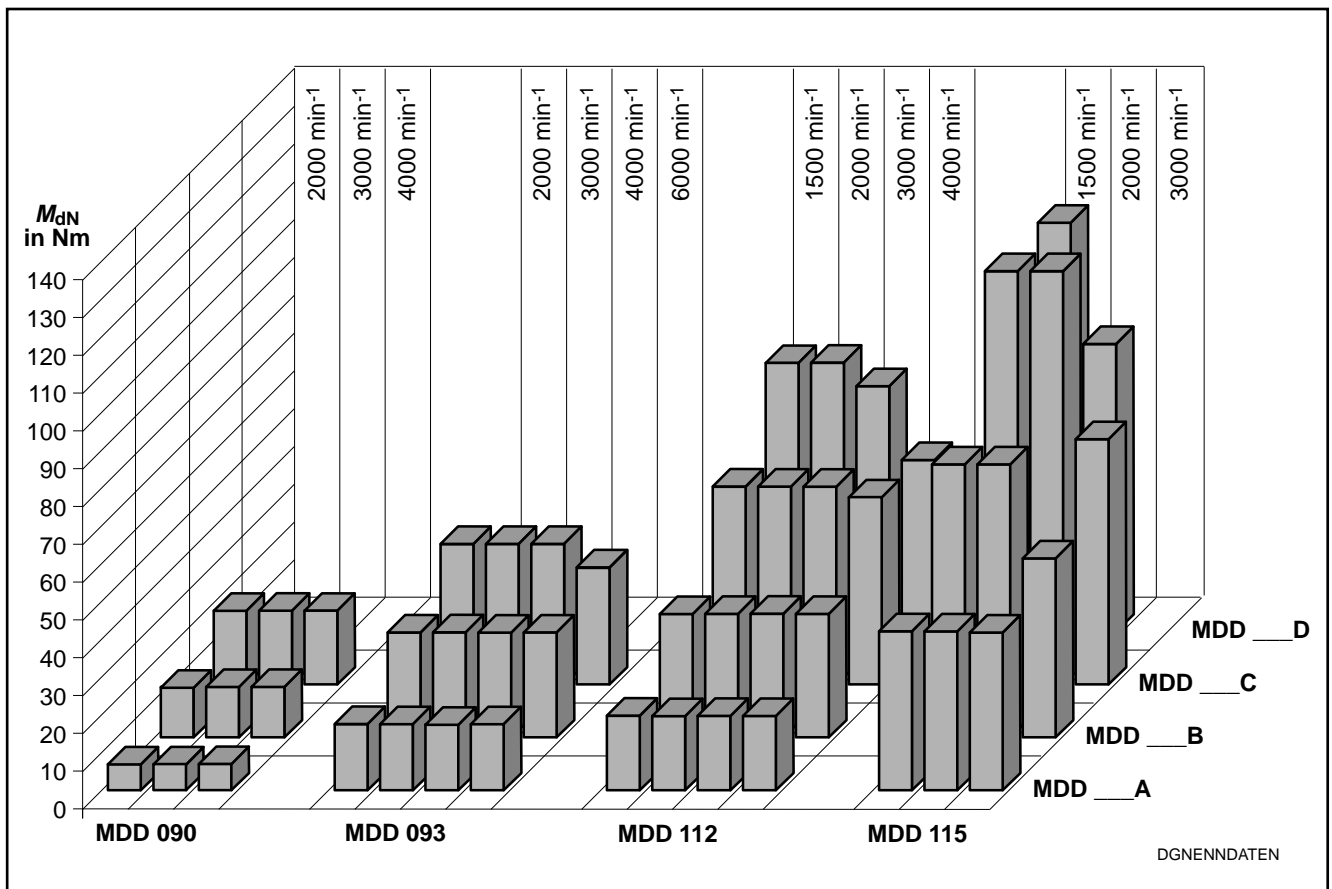


Figure 1.1: A performance overview

Construction The liquid-cooled digital MDD AC servo motors are permanent magnet-excited motors with electronic commutation. The permanent magnets of the rotor are made up of magnetic materials which make it possible to construct a motor with low inertia.

The motors are equipped with a motor feedback, for position and speed evaluation and rotor position recognition, especially developed for this series.

Motor feedback The motor feedback is available with either

- relative, or,
- absolute position evaluation.

The motor feedback has data storage capabilities for motor parameters storage. This means that the drive can be operated without damaging the motor.

Operating reliability

- A brushless design and lifetime lubricated bearings mean maintenance-free operation.
- The motor can be used directly within the working area of the machine even under poor environmental conditions (e.g., affects of coolants, oil emulsions). This is possible because both the motor and the connections for the motor power and feedback cables are totally sealed (as per protection category IP 65).
- Motor temperature monitoring by means of a temperature sensor built into the motor windings prevents overload damage to the intelligent digital drive.

Performance data

- A favorable torque-inertia ratio means high precision.
- The motor has high overload capabilities due to efficient heat conduction from the stator windings to the outside wall of the motor housing.
- Peak torque is utilized over a wide speed range.
- A high power to weight ratio because of the compact construction.
- High cyclic load capacity permits continuous start-stop operations with high repetition rates. This is due to the electronic commutation of the motor.
- The sinusoidal application of current with high motor feedback resolution means high synchronizing characteristics.

Easy mounting to the machine

- Direct attachment of pinions and belt pulleys to the shaft because the design makes it possible to apply high radial loads.
- There is a defined load assimilation of outside forces at the motor shaft. This means that the floating bearing of side A of the motor absorbs the radial forces, while the fixed bearing of side B absorbs the axial forces.
- Thermal deformations in the motor affect side A.
- The motor can be installed in any orientation.
- Flange design with drill holes permits mounting as per design IMB5, or as per design IMB14 with windings in the flange.
- A wide variety of ready-made cables is available eliminating additional installation work.

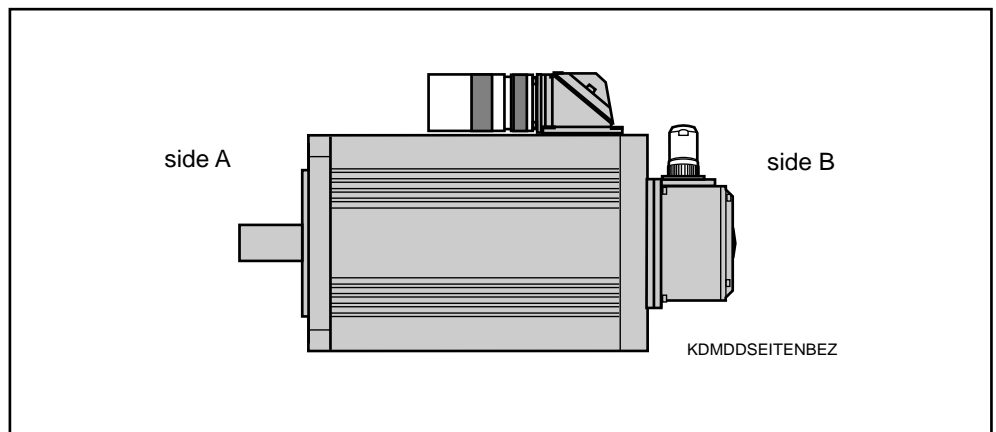


Figure 1.2: Labelling the sides of an MDD servo motor

2. General technical information

2.1. Environmental conditions

*Installation altitude,
ambient temperature*

The power ratings listed in the selection guides are achieved under the following conditions:

- ambient temperature: +5 to +45 °C
- installation altitude: 0 to 1000 meters above sea level

There is a drop in the power ratings as outlined in the diagram in Figure 2.1 under conditions other than those listed. If the ambient temperature and installation altitude both deviate simultaneously, than it is necessary to multiply both power factors.

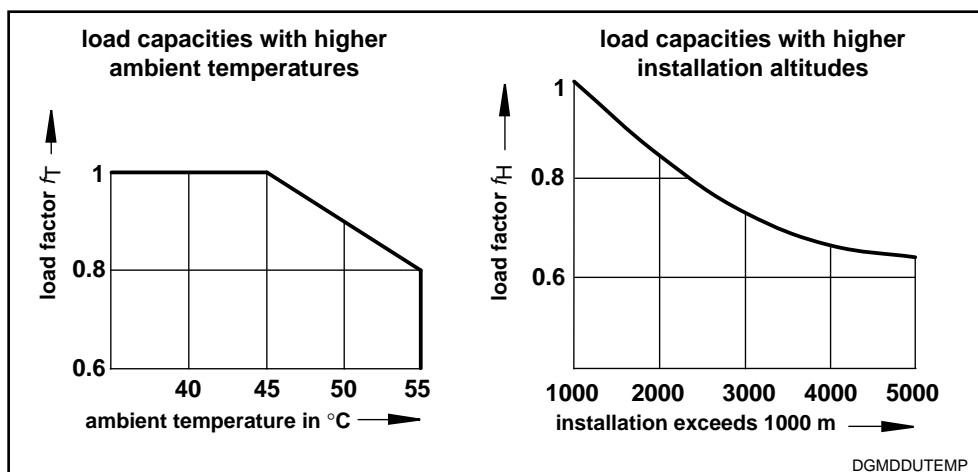


Figure 2.1: Load capacities with higher ambient temperatures and greater altitudes

Protection category

Liquid-cooled MDD servo motors are protected by their housing and covers as per DIN VDE 0470, section 1 (edition dated 11/92) against:

- contact with live or moving parts
- penetration by objects and water

The protection categories are indicated in terms of the letters IP (International Protection) and two digits for the grade of protection. The category for liquid-cooled MDD servo motors is IP65:

- for the housing,
- the drive shaft, and,
- the power and feedback connections.

The first digit defines the protection level against contact and penetration. The digit 6 means:

- protection against penetration by dust (dust-proof), and,
- complete protection against contact.

The second digit defines the protection level against water. The digit 5 means:

- protection against a jet of water, coming from all directions and directed at the housing through a nozzle (a jet of water).

2.2. Motor feedback

Digital MDD AC servo motors are available with two different motor feedbacks:

- either digital servo feedback, or,
- digital servo feedback with integrated multiturn absolute encoder.

The dimensions of both are identical.

Motor feedback data

Designation	Data
measuring principle	optical system
position resolution on the motor	$256 \times 2^{13} = 2\,097\,512$ increments/revolutions
system accuracy	± 0.5 angular minutes
evaluation range with absolute position evaluation	4096 RPMs of the motor

Figure 2.2: DSF motor feedback data

Digital servo feedback (DSF)

This version permits a **relative indirect evaluation of position** on the motor. The relative position is stored in the intelligent digital drive controller. It can be handed over to the NC master control. This eliminates the need for a separate incremental encoder on the motor. The absolute position of the axis is lost when power is shut down. Powering up requires renewed homing.

This version is also used with a **relative direct evaluation of position** on the machine.

Digital servo feedback (DSF) with integrated multiturn absolute encoder (MTG)

This version permits an **absolute indirect evaluation of position** on the motor. The absolute position is stored in the intelligent digital drive and can be handed over to the NC master control. This eliminates the need for a separate absolute encoder on the motor. The absolute position of the axis is maintained when power is shut off.

This version is also used with a **relative direct evaluation of position** on the machine, combined with an absolute position evaluation on the motor.

2.3. Mechanical features

Output direction of the power connection

The output direction of the power connection can be selected in terms of the application, in other words, in accordance with the conditions at the machine. The following variations are available:

- connector towards side A
- connector towards side B
- connector to the right (view from the front onto the motor shaft, connecting housing on top)
- connector to the left (view from the front onto the motor shaft, connecting housing on top)

Centering diameters

The following diameters are available to increase compatibility with the motors of other manufacturers:

For the MDD 112 and 115

- \varnothing 130 mm (standard)
- \varnothing 180 mm

For the MDD 090 and 093

- \varnothing 110 mm (standard)
- \varnothing 130 mm

Output shaft

Plain output shaft (standard)

This achieves a torque transmission free of backlash with a non-positive connection. Clamping sets, pressure sleeves or similar clamping components can be used for coupling in pinions, belt pulleys or similar elements.



We recommend the use of plain shafts with friction-locked connections.

Output shaft with keyway per DIN 6885, sheet 1 (edition dated 8/68)

This achieves a form-fitting torque transmission. This type of shaft-hub connection is suitable for lesser demands. Multi-axial stress occurs at the shaft-hub connection due to torsion, bending, radial and axial loads. During powerful reverse operations, the bottom of the key can turn out and reduce the quality of concentricity. Ever-increasing deformations can cause fractures.

Radial shaft load

The radial shaft load as relates to

- average speed
- and point of application of force

is depicted in section 3. Bearing lifespan was based on 30,000 working hours (calculations per ISO 281, edition dated 12/90).

Axial shaft load

The axial shaft load is outlined in section 3.



Thermal deformations affect side A of the motor. This means that the A side of the motor shaft end can shift up to 0.6 mm with respect to the motor housing. As a result there is a shifting of position

- **of drive pinions with helical teeth mounted to the motor output shaft but not axially fixed to the machine, or,**
- **of drive pinions with helical teeth axially fixed to the machine with bevel gear pinions on which thermal stress can occur. The latter can lead to damage on side B of the motor.**

Holding brake

The motors are available with holding brakes for a backlash-free holding off of the servo axis when no voltage is being applied. The holding brakes developed for this motor series operate on the closed-circuit current principle. At zero current, a magnetic force acts on the brake armature disc. This means that the brake is locked and holding off the axis. With the application of 24V DC, the electrical field cancels the permanent magnetic field and the brake opens.

The holding brake is available with different torques depending upon the type of motor (see technical data).

The digital, intelligent drive controls the holding brake. This maintains the on and off sequence in all operating states. Current measurements in the drive monitor the release of the holding brake. The moment of clamping of an E-stop or fault situation can be selected via parameters to suit the application:

- for example, either immediate clamping,
- clamping after speed falls below 10 min^{-1} , or,
clamping after 400 ms -- even if speed exceeds 10 min^{-1} .



The holding brake is not a working brake. It wears down after approximately 20,000 revolutions against the closed brake.



DDS intelligent digital drives with ANALOG interface achieve a drift-free standstill of the drive via a switching signal. The drive-internal speed control holds the standstill position at zero without drift as long as the drives are active.

Balance class

It is possible to select the balance class for various motor applications in accordance with DIN ISO 2373.

- class N (standard):
 - for normal applications
- class R:
 - for more demanding applications, e.g., grinding machines, or
 - servo drives in main drive applications, e.g., drive tools on lathes.

These classes apply to an A side of a motor shaft without attachments.

2.4. Electrical features

Terminal diagram (schematic)

The terminal diagram depicted in Figure 2.3 is a schematic representation. It is the checklist for all electrical connections required to operate a liquid-cooled MDD servo motor.

INDRAMAT MDD servomotors have standard electrical connections. This restricts the variety of conductors. Sections 4 and 5 list the electrical connections for all specific applications.

The following electrical connections are on the main spindle motor:

- power supply for temperature sensor and holding brake, and,
- motor feedback connection.

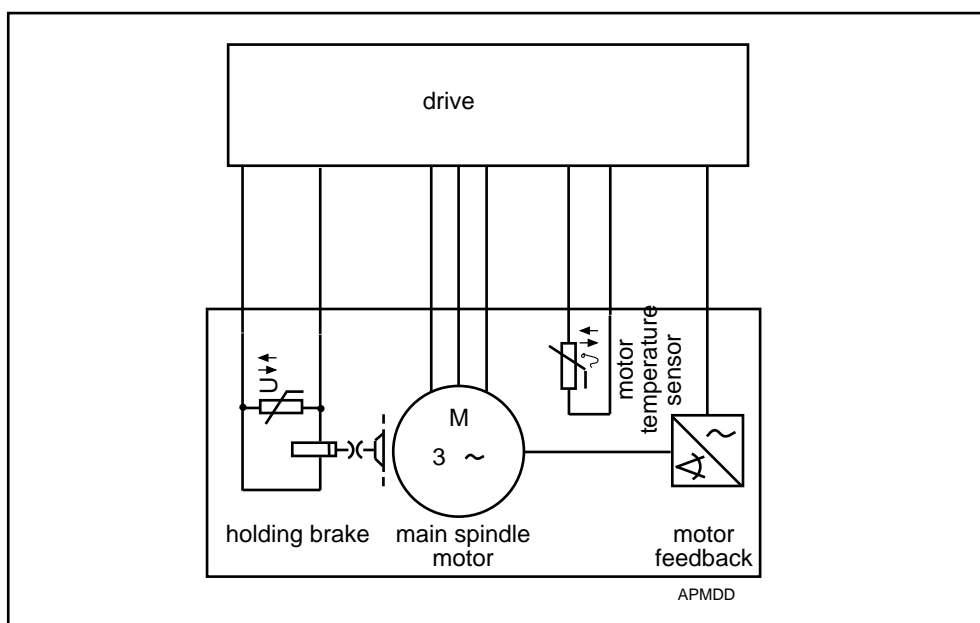


Figure 2.3: Schematic representation of main spindle motor terminal diagram

Motor power connector

Motor power connectors are available for the electrical power connections for:

- crimping, or,
- soldering.

Motor power cables with metric cross sections can be either crimped or soldered to the power connector. Those with inch cross sections can only be soldered.

Feedback connector

Straight or elbow connectors are available to connect the motor feedback, depending upon installation requirements.

Elbow connector The elbow connectors are manufactured at the plant so that the cable output direction is the B side of the motor.

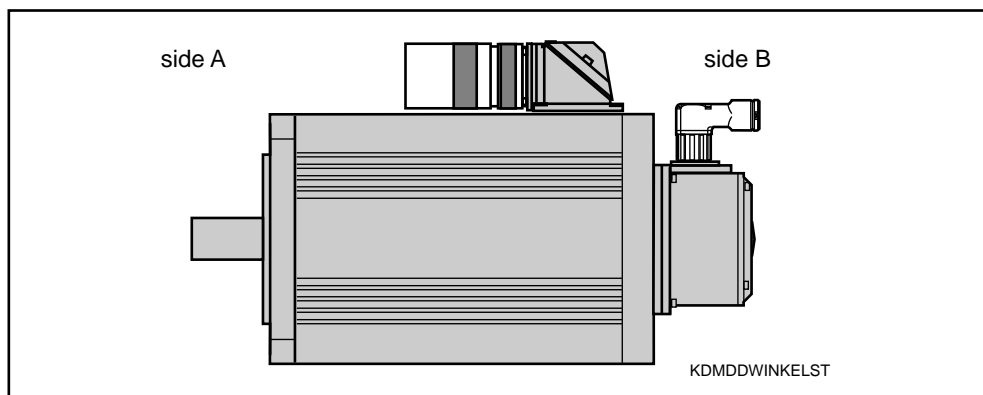


Figure 2.4: Standard cable output direction if elbow connectors are used

The plug connector with screw cap can be turned in increments of 90° once the four fixing screws of the connector housing are released.



Do not damage the seal and cable strands when tightening the screws.

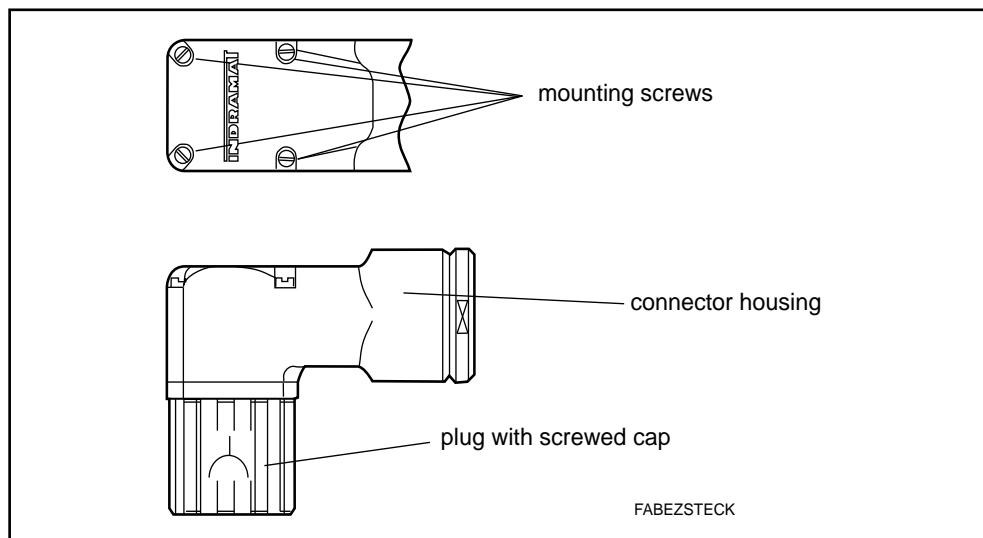


Figure 2.5: Identifying the individual parts of the connectors

2.5. Torque-speed characteristics curves

These curves depict

- the torque limiting values,
- the speed limiting values, and,
- the operating characteristics curves of each motor type.

<i>Torque limiting values</i>	The horizontal line, M_{\max} , describes the theoretically possible maximum torque of the motor. The drive can limit this maximum torque. The maximum torque resulting from the various motor-drive combinations is outlined in the selection guides.
<i>Speed limiting values</i>	<p>Maximum motor speed is determined by the DC bus voltage produced by the power source on the drive.</p> <p>Depending upon the DC bus voltage on the drive, maximum torque drops at a breaking point. These dropping curves are allocated as follows:</p> <ul style="list-style-type: none"> - [1] - DC bus voltage with a regulated power supply (e.g., KDV 4, TVD, KVR, TVR), or an unregulated power supply (e.g., TVM2, KDV 1, KDV 2, KDV 3, DKS), if AC mains input voltage is 10% higher than the rated 3 x 230 V AC. - [2] - DC bus voltage with an unregulated power supply (e.g., TVM 2, KDV 1, KDV 2, KDV 3, DKS) connected to threephase mains rated at 3 x 230 V. - [3] - DC bus voltage with an unregulated power supply (e.g., TVM 2, KDV 1, KDV 2, KDV 3, DKS), if the AC mains input voltage is 10% less than the rated 3 x 230 V AC. - [4] - DC bus voltage with an unregulated power supply (e.g., DKS), if AC mains input voltage is connected to a single phase mains rated at 1 x 230 V AC. - [5] - DC bus voltage with an unregulated supply (e.g., DKS), if the AC mains input voltage is 10% less than the rated 1 x 230 V AC.
<i>Operating curves</i>	The operating characteristics curves depict the permissible continuous torque of the liquid-cooled motor (S1 operating mode per DIN 57530/VDE 0530).

Application The speed-torque characteristics curves can be used:

- to record information from the selection documentation,
- to determine the possible maximum usable speed for a special application with known torque requirements,
- and to check whether the application remains within the thermal limits of the motor. The root-mean-square torque for a critical cycle must be below the S1-continuous operating characteristic curve of the arithmetically averaged speed.

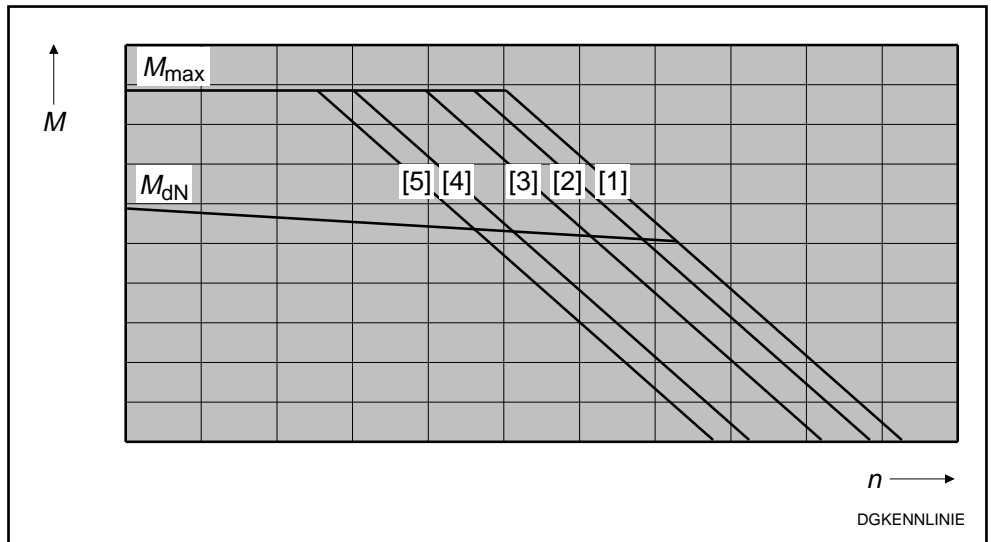


Figure 2.6: Schematic diagram of the torque-speed characteristics curves

3. Technical data

3.1. MDD 090 (liquid-cooled)

3.1.1. MDD 090 motor data

Designation	Symbol	Unit			
			090A-F-020	090A-F-030	090A-F-040
Motor type MDD . . .			090A-F-020	090A-F-030	090A-F-040
Basic motor speed ¹⁾	n	min ⁻¹	2000	3000	4000
Continuous stall torque	M_{dN}	Nm	6.9	6.9	6.9
Continuous stall current	I_{dN}	A	7.4	11.7	17.7
Theor. maximum speed ²⁾	M_{max}	Nm	19.0	17.8	15.1
Peak current	I_{max}	A	21.9	32.2	41.3
Rotor inertia ³⁾	J_M	kgm ²	0.0020	0.0020	0.0020
Torque constant at 20 °C	K_m	Nm/A	0.93	0.59	0.39
Windings resistance at 20 °C	R_A	Ohm	6.84	3.08	1.30
Windings inductance	L_A	mH	27.7	13.4	7.7
Thermal time constant	T_{th}	min	20	20	20
Mass ³⁾	m_M	kg	12.5	12.5	12.5
Rated power loss	P_{vN}	W	420		
Ambient temperature ⁴⁾	ϑ_{amb}	°C	+5° to +45°		
Coolant entry temperature	ϑ_{ein}	°C	+10° to +40°		
Coolant temperature increase with P_{vN}	$\Delta\vartheta_N$	°C	10		
Minimum coolant flowthrough with $\Delta\vartheta_N$ ⁵⁾	Q_N	l/min	0.6		
Pressure drop with Q_N ^{5) 6)}	Δp_N	bar	0.3		
Maximum system pressure	p_{max}	bar	3		
Volume in coolant canal	V	l			
Storage and transportation temperature ⁷⁾	ϑ_L	°C	-20° to +80°		
Maximum installation altitude		m	1000 meters above sea level		
Protection category			IP 65		
Insulation classification			F		
Housing finish			prime coat black (RAL 9005)		
<u>options</u> <u>holding brake, electrical release</u>					
Holding torque	M_H	Nm	6.5		11
Rated voltage	U_N	V	24 ± 10%		24 ± 10%
Rated current	I_N	A	0.65		0.65
Inertia	J_B	kgm ²	1.06 x 10 ⁻⁴		1.06 x 10 ⁻⁴
Release delay	t_L	ms	60		60
Clamping delay	t_K	ms	20		20
Mass	m_B	kg	0.5		0.5
¹⁾ Usable motor speed is determined by the torque requirements of the application. The usable speeds n_{max} found in the selection lists of the motor-drive combinations are binding for standard applications. The usable speeds for other applications can be found using the required torque in the torque-speed characteristics curves. ²⁾ The maximum achievable torque depends upon the drive used. Only those maximum torques M_{max} found in the selection list of the motor-drive combinations are binding. ³⁾ Without holding brake. ⁴⁾ Note the relationship between the actual ϑ_{amb} and the ϑ_{ein} : ϑ_{ein} may be no more than 5 °C below ϑ_{amb} ! ⁵⁾ With coolant water. ⁶⁾ Note flow diagram for deviating flow values. ⁷⁾ Empty of all coolant prior to transportation or storage.					

Figure 3.1: MDD 090A (liquid-cooled) - technical data

3. Technical data

Designation	Symbol	Unit				
Motor type MDD . . .			090B-F-020	090B-F-030	090B-F-040	
Basic motor speed ¹⁾	n	min ⁻¹	2000	3000	4000	
Continuous stall torque	M_{dN}	Nm	13.5	13.5	13.5	
Continuous stall current	I_{dN}	A	15.7	23.7	31.4	
Theor. maximum speed ²⁾	M_{max}	Nm	39.1	38.8	38.3	
Peak current	I_{max}	A	48.6	72.9	95.3	
Rotor inertia ³⁾	J_M	kgm ²	0.0036	0.0036	0.0036	
Torque constant at 20 °C	K_m	Nm/A	0.86	0.57	0.43	
Windings resistance at 20 °C	R_A	Ohm	1.99	0.91	0.50	
Windings inductance	L_A	mH	10.1	4.7	2.6	
Thermal time constant	T_{th}	min	30	30	30	
Mass ³⁾	m_M	kg	18	18	18	
Rated power loss	P_{vN}	W	510			
Ambient temperature ⁴⁾	ϑ_{amb}	°C	+5° to +45°			
Coolant entry temperature	ϑ_{ein}	°C	+10° to +40°			
Coolant temperature increase with P_{vN}	$\Delta\vartheta_N$	°C	10			
Minimum coolant flow through with $\Delta\vartheta_N$ ⁵⁾	Q_N	l/min	0.7			
Pressure drop with Q_N ^{5) 6)}	Δp_N	bar	0.33			
Maximum system pressure	p_{max}	bar	3			
Volume in coolant canal	V	l				
Storage and transportation temperature ⁷⁾	ϑ_L	°C	-20° to +80°			
Maximum installation altitude		m	1000 meters above sea level			
Protection category			IP 65			
Insulation classification			F			
Housing finish			prime coat black (RAL 9005)			
<u>options</u>						
<u>holding brake, electrical release</u>						
Holding torque	M_H	Nm	6.5		11	
Rated voltage	U_N	V	24 ± 10%		24 ± 10%	
Rated current	I_N	A	0.65		0.65	
Inertia	J_B	kgm ²	1.06 x 10 ⁻⁴		1.06 x 10 ⁻⁴	
Release delay	t_L	ms	60		60	
Clamping delay	t_K	ms	20		20	
Mass	m_B	kg	0.5		0.5	
<p>¹⁾ Usable motor speed is determined by the torque requirements of the application. The usable speeds n_{max} found in the selection lists of the motor-drive combinations are binding for standard applications. The usable speeds for other applications can be found using the required torque in the torque-speed characteristics curves.</p> <p>²⁾ The maximum achievable torque depends upon the drive used. Only those maximum torques M_{max} found in the selection list of the motor-drive combinations are binding.</p> <p>³⁾ Without holding brake.</p> <p>⁴⁾ Note the relationship between the actual ϑ_{amb} and the ϑ_{ein}; ϑ_{ein} may be no more than 5 °C below ϑ_{amb}!</p> <p>⁵⁾ With coolant water.</p> <p>⁶⁾ Note flow diagram for deviating flow values.</p> <p>⁷⁾ Empty of all coolant prior to transportation or storage.</p>						

Figure 3.2: MDD 090B (liquid-cooled) - technical data

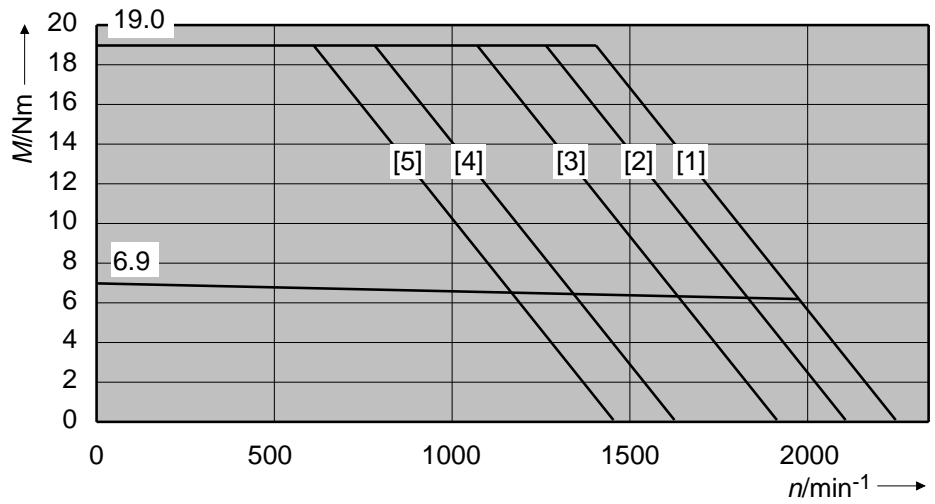
3. Technical data

Designation	Symbol	Unit			
			090C-F-020	090C-F-030	090C-F-040
Motor type MDD . . .					
Basic motor speed ¹⁾	n	min ⁻¹	2000	3000	4000
Continuous stall torque	M_{dN}	Nm	19.5	19.5	19.5
Continuous stall current	I_{dN}	A	22.7	36.8	45.3
Theor. maximum speed ²⁾	M_{max}	Nm	58.6	58.3	58.6
Peak current	I_{max}	A	72.9	118	146
Rotor inertia ³⁾	J_M	kgm ²	0.0053	0.0053	0.0053
Torque constant at 20 °C	K_m	Nm/A	0.86	0.53	0.43
Windings resistance at 20 °C	R_A	Ohm	1.20	0.46	0.28
Windings inductance	L_A	mH	6.8	2.6	1.6
Thermal time constant	T_{th}	min	30	30	30
Mass ³⁾	m_M	kg	23	23	23
Rated power loss	P_{vN}	W	620		
Ambient temperature ⁴⁾	ϑ_{amb}	°C	+5° to +45°		
Coolant entry temperature	ϑ_{ein}	°C	+10° to +40°		
Coolant temperature increase with P_{vN}	$\Delta\vartheta_N$	°C	10		
Minimum coolant flow through with $\Delta\vartheta_N$ ⁵⁾	Q_N	l/min	0.9		
Pressure drop with Q_N ^{5) 6)}	Δp_N	bar	0.4		
Maximum system pressure	p_{max}	bar	3		
Volume in coolant canal	V	l			
Storage and transportation temperature ⁷⁾	ϑ_L	°C	-20° to +80°		
Maximum installation altitude		m	1000 meters above sea level		
Protection category			IP 65		
Insulation classification			F		
Housing finish			prime coat black (RAL 9005)		
options <u>holding brake, electrical release</u>					
Holding torque	M_H	Nm	6,5		11
Rated voltage	U_N	V	24 ± 10%		24 ± 10%
Rated current	I_N	A	0.65		0.65
Inertia	J_B	kgm ²	1.06 x 10 ⁻⁴		1.06 x 10 ⁻⁴
Release delay	t_L	ms	60		60
Clamping delay	t_K	ms	20		20
Mass	m_B	kg	0.5		0.5
<p>¹⁾ Usable motor speed is determined by the torque requirements of the application. The usable speeds n_{max} found in the selection lists of the motor-drive combinations are binding for standard applications. The usable speeds for other applications can be found using the required torque in the torque-speed characteristics curves.</p> <p>²⁾ The maximum achievable torque depends upon the drive used. Only those maximum torques M_{max} found in the selection list of the motor-drive combinations are binding.</p> <p>³⁾ Without holding brake.</p> <p>⁴⁾ Note the relationship between the actual ϑ_{amb} and the ϑ_{ein}: ϑ_{ein} may be no more than 5 °C below ϑ_{amb}!</p> <p>⁵⁾ With coolant water.</p> <p>⁶⁾ Note flow diagram for deviating flow values.</p> <p>⁷⁾ Empty of all coolant prior to transportation or storage.</p>					

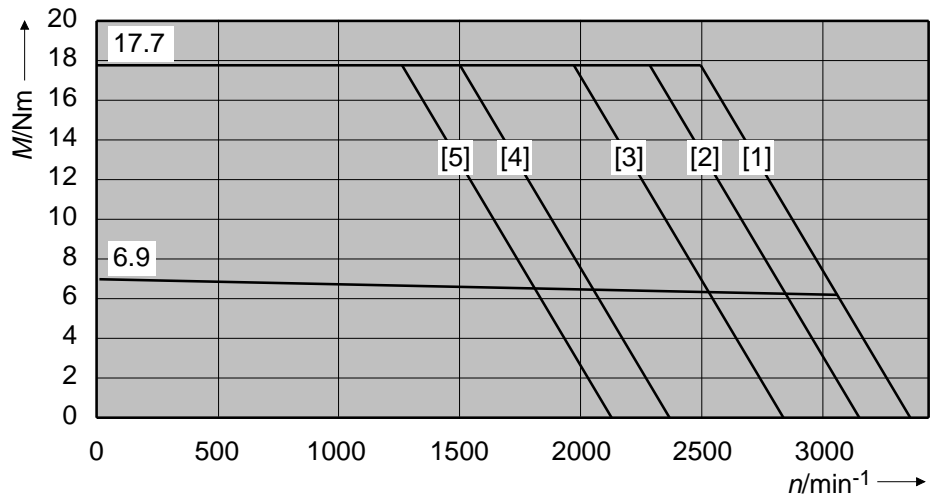
Figure 3.3: MDD 090C (liquid-cooled) - technical data

3.1.2. MDD 090 torque-speed characteristics curves

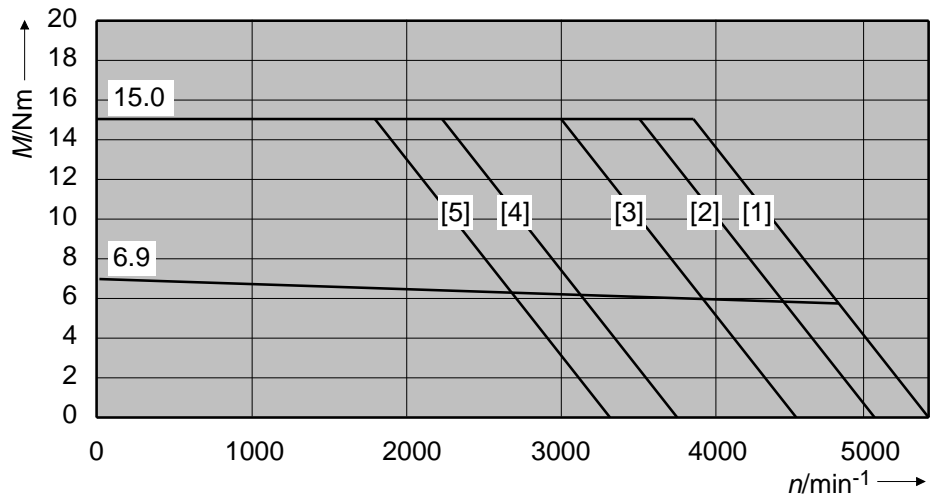
*MDD 090A-F
with 2000 min⁻¹*



*MDD 090A-F
with 3000 min⁻¹*



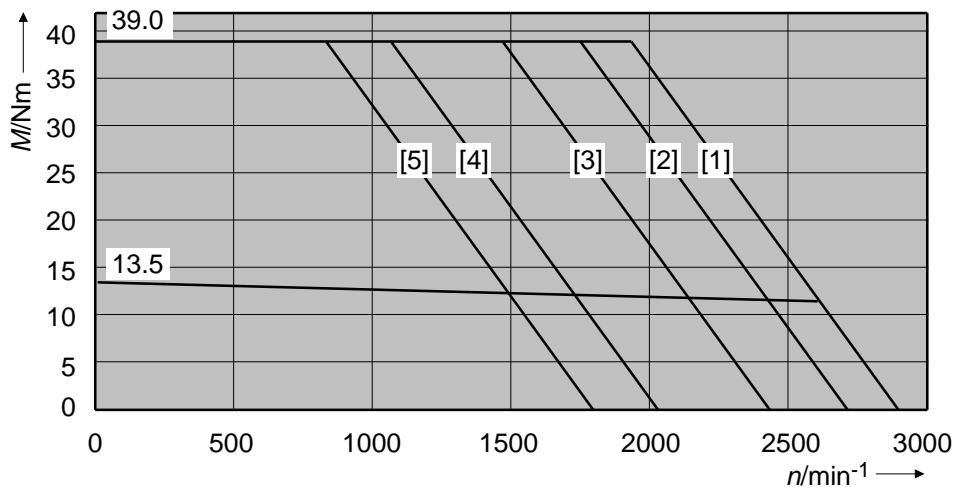
*MDD 090A-F
with 4000 min⁻¹*



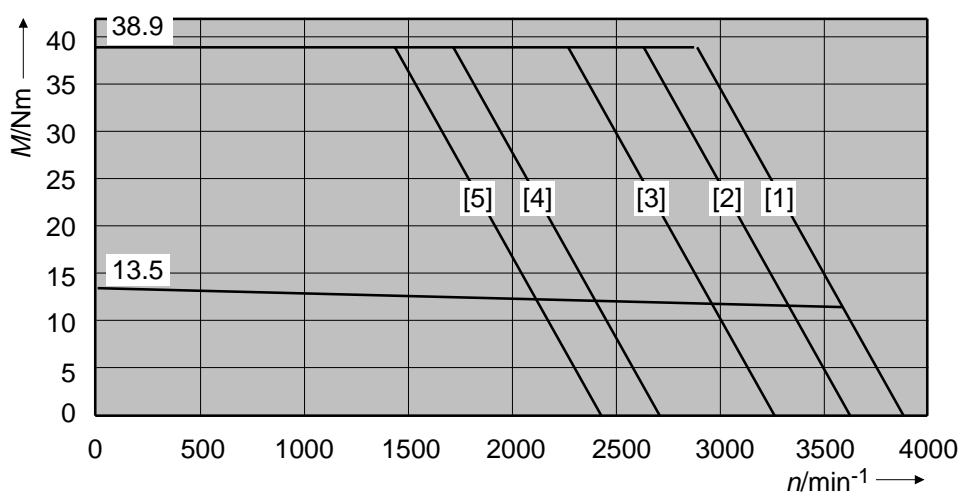
DGMDD090A

Figure 3.4: MDD 090A - characteristics curves

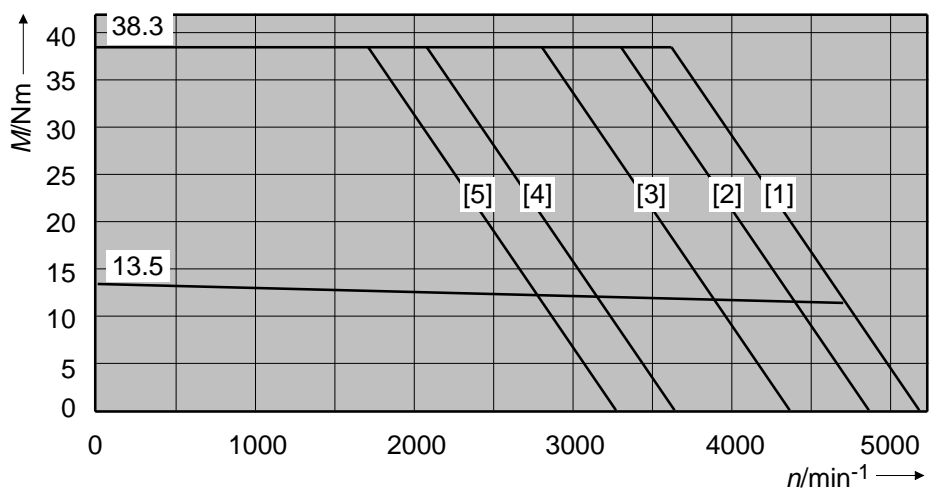
*MDD 090B-F
with 2000 min⁻¹*



*MDD 090B-F
with 3000 min⁻¹*



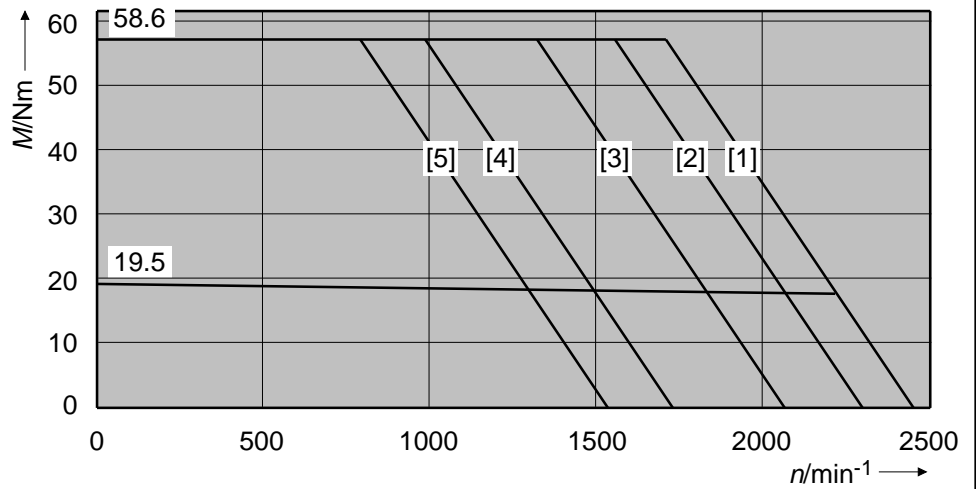
*MDD 090B-F
with 4000 min⁻¹*



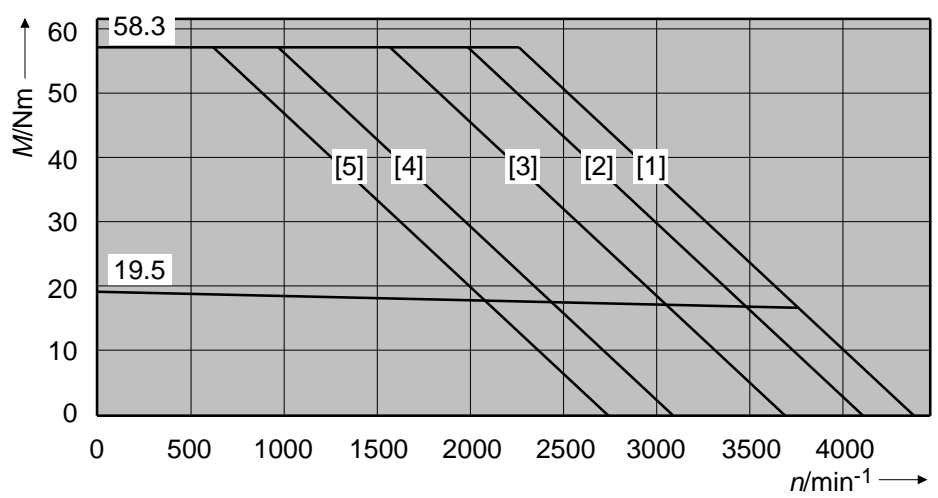
DGMDD090B

Figure 3.5: MDD 090B - characteristics curves

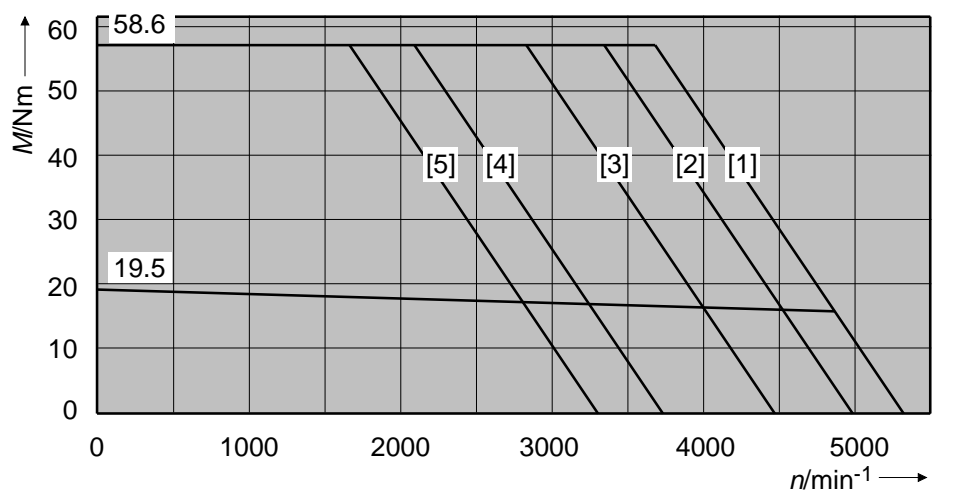
*MDD 090C-F
with 2000 min⁻¹*



*MDD 090C-F
with 3000 min⁻¹*



*MDD 090C-F
with 4000 min⁻¹*



DGMDD090C

Figure 3.6: MDD 090C - characteristics curves

3.1.3. MDD 090 - shaft load

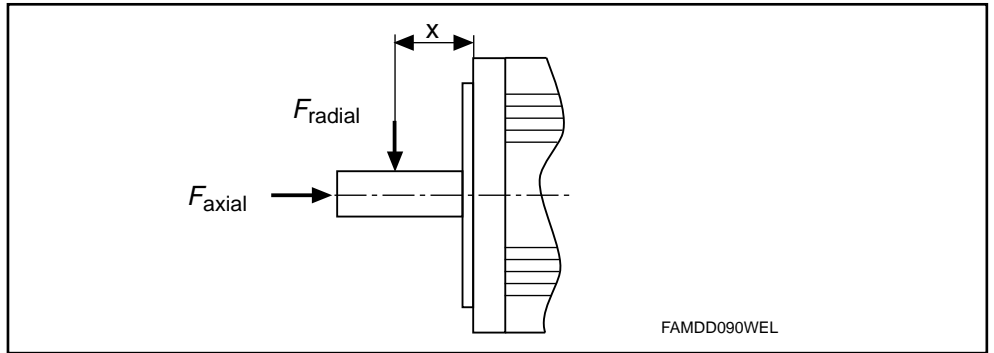


Figure 3.7: Shaft load

Radial force F_{radial}

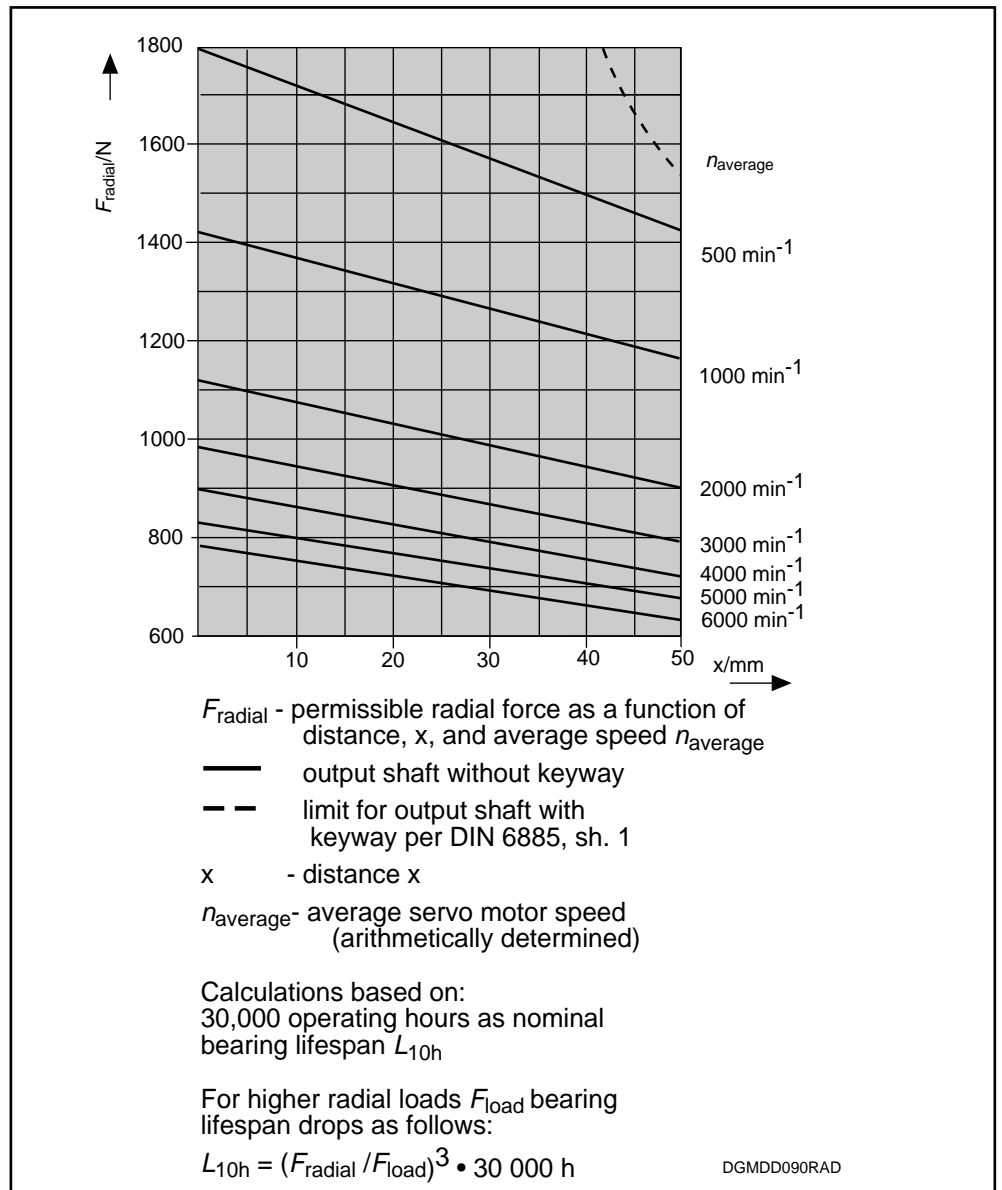


Figure 3.8: Radial force

Axial force F_{axial}

$$F_{axial} = 0.34 \cdot F_{radial}$$

F_{axial} - permissible axial force

F_{radial} - permissible radial force

3.1.4. MDD 090 - dimensional data

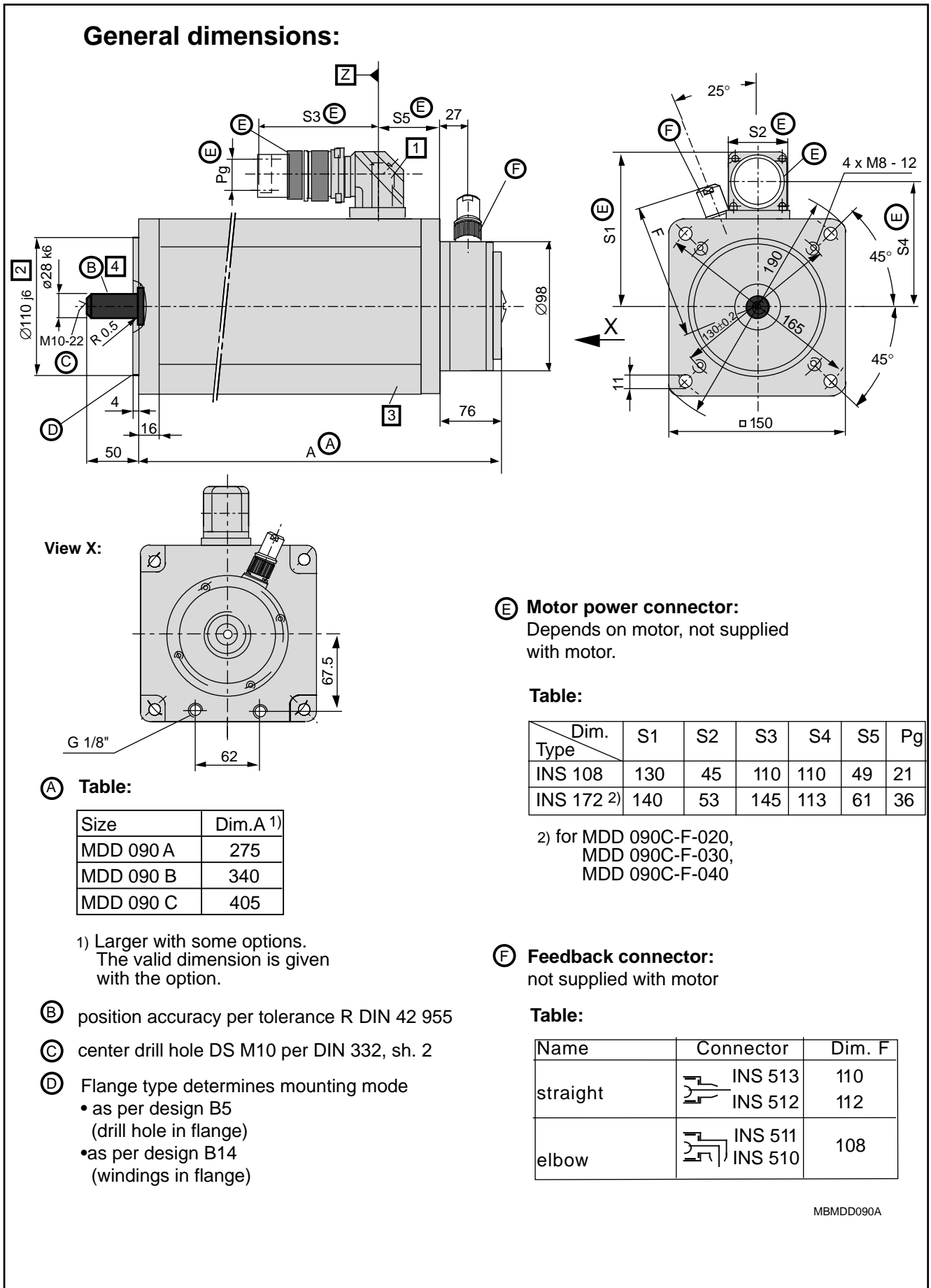


Figure 3.9: MDD 090 (liquid-cooled) - general dimensional data

Option-dependent dimensions:

1 Mounting direction of the motor power connector:

- to side A
- to side B
- to the right } looking towards the
- to the left } motor shaft

Side A is depicted as the output direction in the figure. The dimensions for other output directions are obtained by turning the connector housing around the Z axis.

2 Custom centering diameter:

- $\varnothing 130 \text{ j6}$

3 Holding brake:

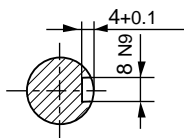
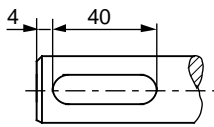
- Holding torque: 6.5 Nm
- Holding torque: 11 Nm

Table for 6.5 and 11 Nm holding torque
--

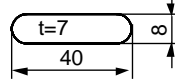
does not affect outer dimensions

4 Output shaft:

- plain shaft (preferred type)
- with keyway per DIN 6885, sh.1 (Note: balanced with entire key!)



matching key: DIN 6885-A 8x7x40



MBMDD0900

Figure 3.10: MDD 090 (liquid-cooled) options-dependent data

3.1.5. MDD 090 - type codes

Type code fields	Example:	M	D	D	0	9	0	B	-	F	-	0	2	0	-	N	2	L	-	1	1	0	G	B	0	/	S	0	0	0
1. Name Motor for digital drives	MDD																													
2. Motor size	090																													
3. Motor length	A, B, C																													
4. Housing: for liquid-cooling	F																													
5. Basic speed 2000 min ⁻¹ 3000 min ⁻¹ 4000 min ⁻¹	020 030 040																													
6. Balance class N per DIN ISO 2373 R per DIN ISO 2373	N R																													
7. shaft end on side B standard (no second shaft end)	2																													
8. Motor feedback digital servo feedback digital servo feedback with integrated multiturn encoder	L M																													
9. Centering diameter ø110 mm ø130 mm	110 130																													
10. Output shaft plain shaft shaft with keyway per DIN 6885, sheet 1	G P																													
11. Output direction of the power connection connector towards side A connector towards side B connector to the right (view from front onto motor shaft, connector housing on top) connector to the left (view from front onto motor shaft, connector housing on top)	A B R L																													
12. Holding brake no holding brake with holding brake of 6.5 Nm with holding brake of 11.0 Nm	0 1 2																													
13. Custom versions Determined and documented by INDRAMAT with custom number. Type key field 13 does not apply to standard motors.																														

Figure 3.11: MDD 090 (liquid-cooled) - available options

3.2. MDD 093 (liquid-cooled)

3.2.1. MDD 093 - motor data

Designation	Symbol	Unit				
			093A-F-020	093A-F-030	093A-F-040	093A-F-060
Motor type MDD . . .						
Basic motor speed ¹⁾	n	min ⁻¹	2000	3000	4000	6000
Continuous stall torque	M_{dN}	Nm	17.5	17.5	17.5	17.5
Continuous stall current	I_{dN}	A	19.3	33.7	44.3	70.0
Theor. maximum speed ²⁾	M_{max}	Nm	28.5	28.7	28.2	28.6
Peak current	I_{max}	A	45.8	79.9	104.8	165.8
Rotor inertia ³⁾	J_M	kgm ²	0.0022	0.0022	0.0022	0.0022
Torque constant at 20 °C	K_m	Nm/A	0.90	0.52	0.39	0.25
Windings resistance at 20 °C	R_A	Ohm	1.86	0.61	0.38	0.16
Windings inductance	L_A	mH	15.3	4.9	2.8	1.9
Thermal time constant	T_{th}	min	25	25	25	25
Mass ³⁾	m_M	kg	13	13	13	13
Rated power loss	P_{vN}	W	730			
Ambient temperature ⁴⁾	ϑ_{amb}	°C	+5 to +45			
Coolant entry temperature	ϑ_{ein}	°C	+10 to +40			
Coolant temperature increase with P_{vN}	$\Delta\vartheta_N$	°C	10			
Minimum coolant flow through with $\Delta\vartheta_N$ ⁵⁾	Q_N	l/min	1.0			
Pressure drop with Q_N ^{5) 6)}	Δp_N	bar	0.5			
Maximum system pressure	p_{max}	bar	3			
Volume in coolant canal	V	l				
Storage and transportation temperature ⁷⁾	ϑ_L	°C	-20° to +80°			
Maximum installation altitude		m	1000 meters above sea level			
Protection category			IP 65			
Insulation classification			F			
Housing finish			prime coat black (RAL 9005)			
<u>options</u> <u>holding brake, electrical release</u>						
Holding torque	M_H	Nm	11		22	
Rated voltage	U_N	V	24 ± 10%		24 ± 10%	
Rated current	I_N	A	0,5		0.69	
Inertia	J_B	kgm ²	1.06 x 10 ⁻⁴		3.6 x 10 ⁻⁴	
Release delay	t_L	ms	60		70	
Clamping delay	t_K	ms	20		30	
Mass	m_B	kg	0.5		1.1	
<p>1) Usable motor speed is determined by the torque requirements of the application. The usable speeds n_{max} found in the selection lists of the motor-drive combinations are binding for standard applications. The usable speeds for other applications can be found using the required torque in the torque-speed characteristics curves.</p> <p>2) The maximum achievable torque depends upon the drive used. Only those maximum torques M_{max} found in the selection list of the motor-drive combinations are binding.</p> <p>3) Without holding brake.</p> <p>4) Note the relationship between the actual ϑ_{amb} and the ϑ_{ein}: ϑ_{ein} may be no more than 5 °C below ϑ_{amb}!</p> <p>5) With coolant water.</p> <p>6) Note flow diagram for deviating flow values.</p> <p>7) Empty of all coolant prior to transportation or storage.</p>						

Figure 3.12: Technical data for MDD 093A (liquid-cooled)

3. Technical data

Designation	Symbol	Unit				
			093B-F-020	093B-F-030	093B-F-040	093B-F-060
Motor type MDD . . .			093B-F-020	093B-F-030	093B-F-040	093B-F-060
Basic motor speed ¹⁾	n	min ⁻¹	2000	3000	4000	6000
Continuous stall torque	M_{dN}	Nm	27.6	27.6	27.6	27,6
Continuous stall current	I_{dN}	A	32.1	45.7	69.6	88,8
Theor. maximum speed ²⁾	M_{max}	Nm	45.2	44.9	45.5	45,0
Peak current	I_{max}	A	76.0	108	165	210
Rotor inertia ³⁾	J_M	kgm ²	0.0029	0.0029	0.0029	0.0029
Torque constant at 20 °C	K_m	Nm/A	0.86	0.60	0.40	0.31
Windings resistance at 20 °C	R_A	Ohm	0.77	0.43	0.20	0.11
Windings inductance	L_A	mH	11	4.4	1.9	1.1
Thermal time constant	T_{th}	min	25	25	25	25
Mass ³⁾	m_M	kg	16.5	16.5	16.5	16.5
Rated power loss	P_{vN}	W	870			
Ambient temperature ⁴⁾	ϑ_{amb}	°C	+5° to +45°			
Coolant entry temperature	ϑ_{ein}	°C	+10° to +40°			
Coolant temperature increase with P_{vN}	$\Delta\vartheta_N$	°C	10			
Minimum coolant flow through with $\Delta\vartheta_N$ ⁵⁾	Q_N	l/min	1.3			
Pressure drop with Q_N ^{5) 6)}	Δp_N	bar	0.7			
Maximum system pressure	p_{max}	bar	3			
Volume in coolant canal	V	l				
Storage and transportation temperature ⁷⁾	ϑ_L	°C	-20° to +80°			
Maximum installation altitude		m	1000 meters above sea level			
Protection category			IP 65			
Insulation classification			F			
Housing finish			prime coat black (RAL 9005)			
<u>options</u>						
<u>holding brake, electrical release</u>						
Holding torque	M_H	Nm	11		22	
Rated voltage	U_N	V	24 ± 10%		24 ± 10%	
Rated current	I_N	A	0.5		0.69	
Inertia	J_B	kgm ²	1.06 x 10 ⁻⁴		3.6 x 10 ⁻⁴	
Release delay	t_L	ms	60		70	
Clamping delay	t_K	ms	20		30	
Mass	m_B	kg	0.5		1.1	
¹⁾ Usable motor speed is determined by the torque requirements of the application. The usable speeds n_{max} found in the selection lists of the motor-drive combinations are binding for standard applications. The usable speeds for other applications can be found using the required torque in the torque-speed characteristics curves. ²⁾ The maximum achievable torque depends upon the drive used. Only those maximum torques M_{max} found in the selection list of the motor-drive combinations are binding. ³⁾ Without holding brake. ⁴⁾ Note the relationship between the actual ϑ_{amb} and the ϑ_{ein} : ϑ_{ein} may be no more than 5 °C below ϑ_{amb} ! ⁵⁾ With coolant water. ⁶⁾ Note flow diagram for deviating flow values. ⁷⁾ Empty of all coolant prior to transportation or storage.						

Figure 3.13: Technical data for MDD 093B (liquid-cooled)

3. Technical data

Designation	Symbol	Unit				
Motor type MDD . . .			093C-F-020	093C-F-030	093C-F-040	093C-F-060
Basic motor speed ¹⁾	n	min ⁻¹	2000	3000	4000	6000
Continuous stall torque	M_{dN}	Nm	37.1	37.1	37.1	30.9
Continuous stall current	I_{dN}	A	40.7	61.2	86.1	102.9
Theor. maximum speed ²⁾	M_{max}	Nm	60.6	61.1	60.6	60.8
Peak current	I_{max}	A	96.5	145	204	293
Rotor inertia ³⁾	J_M	kgm ²	0.0042	0.0042	0.0042	0.0042
Torque constant at 20 °C	K_m	Nm/A	0.91	0.61	0.43	0.30
Windings resistance at 20 °C	R_A	Ohm	0.56	0.25	0.14	0.07
Windings inductance	L_A	mH	6.1	2.7	1.6	0.7
Thermal time constant	T_{th}	min	25	25	25	25
Mass ³⁾	m_M	kg	22	22	22	22
Rated power loss	P_{vN}	W	970			
Ambient temperature ⁴⁾	ϑ_{amb}	°C	+5° to +45°			
Coolant entry temperature	ϑ_{ein}	°C	+10° to +40°			
Coolant temperature increase with P_{vN}	$\Delta\vartheta_N$	°C	10			
Minimum coolant flow through with $\Delta\vartheta_N$ ⁵⁾	Q_N	l/min	1.4			
Pressure drop with Q_N ^{5) 6)}	Δp_N	bar	0.7			
Maximum system pressure	p_{max}	bar	3			
Volume in coolant canal	V	l				
Storage and transportation temperature ⁷⁾	ϑ_L	°C	-20° to +80°			
Maximum installation altitude		m	1000 meters above sea level			
Protection category			IP 65			
Insulation classification			F			
Housing finish			prime coat black (RAL 9005)			
<u>options</u>						
<u>holding brake, electrical release</u>						
Holding torque	M_H	Nm	11		22	
Rated voltage	U_N	V	24 ± 10%		24 ± 10%	
Rated current	I_N	A	0.5		0.69	
Inertia	J_B	kgm ²	1.06 x 10 ⁻⁴		3.6 x 10 ⁻⁴	
Release delay	t_L	ms	60		70	
Clamping delay	t_K	ms	20		30	
Mass	m_B	kg	0.5		1.1	
<p>1) Usable motor speed is determined by the torque requirements of the application. The usable speeds n_{max} found in the selection lists of the motor-drive combinations are binding for standard applications. The usable speeds for other applications can be found using the required torque in the torque-speed characteristics curves.</p> <p>2) The maximum achievable torque depends upon the drive used. Only those maximum torques M_{max} found in the selection list of the motor-drive combinations are binding.</p> <p>3) Without holding brake.</p> <p>4) Note the relationship between the actual ϑ_{amb} and the ϑ_{ein}: ϑ_{ein} may be no more than 5 °C below ϑ_{amb}!</p> <p>5) With coolant water.</p> <p>6) Note flow diagram for deviating flow values.</p> <p>7) Empty of all coolant prior to transportation or storage.</p>						

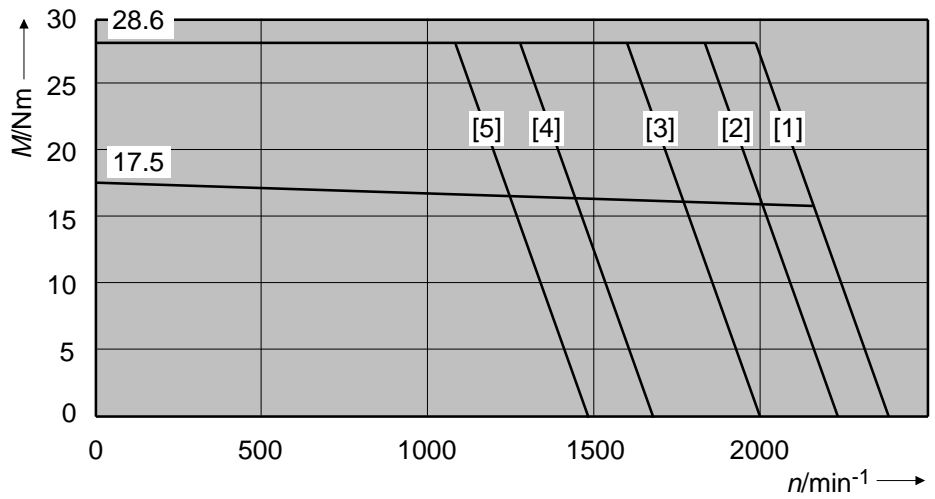
Figure 3.14: Technical data for MDD 093C (liquid-cooled)

in preparation

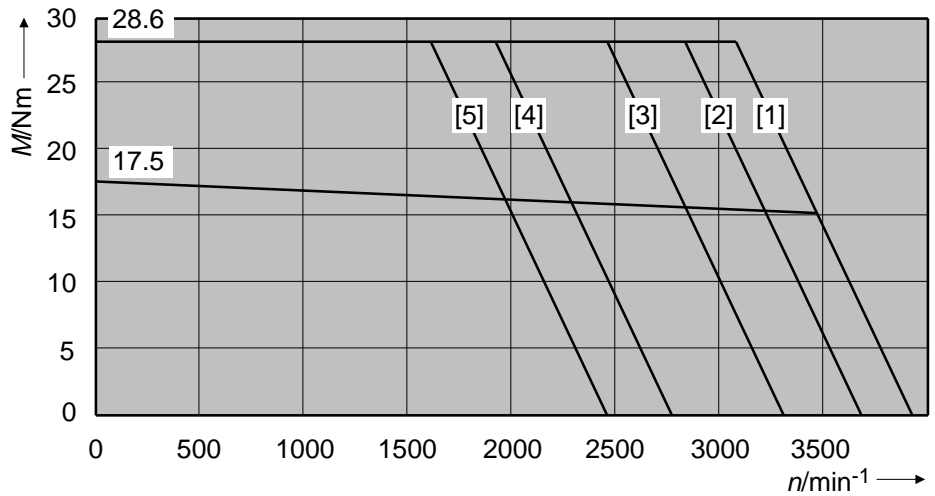
Figure 3.15: Technical data for MDD 093D (liquid-cooled)

3.2.2. MDD 093 - torque-speed characteristics curves

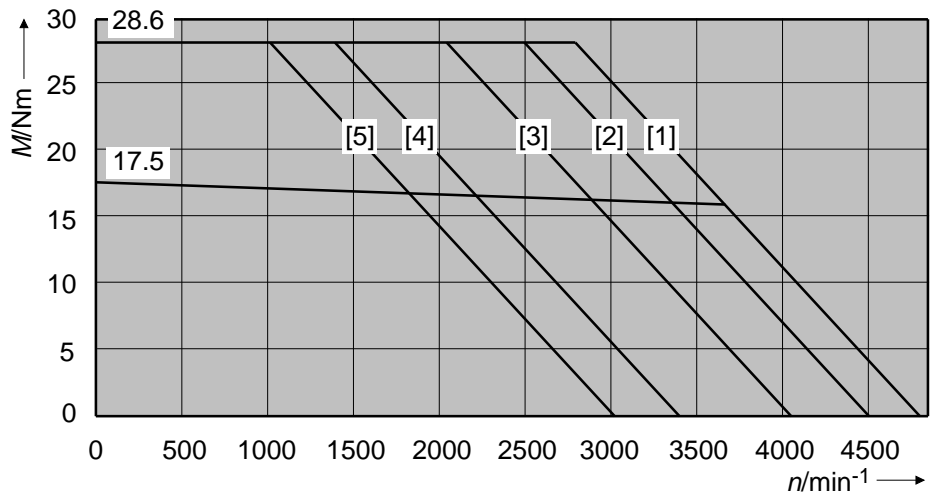
MDD 093A-F
with 2000 min⁻¹



MDD 093A-F
with 3000 min⁻¹



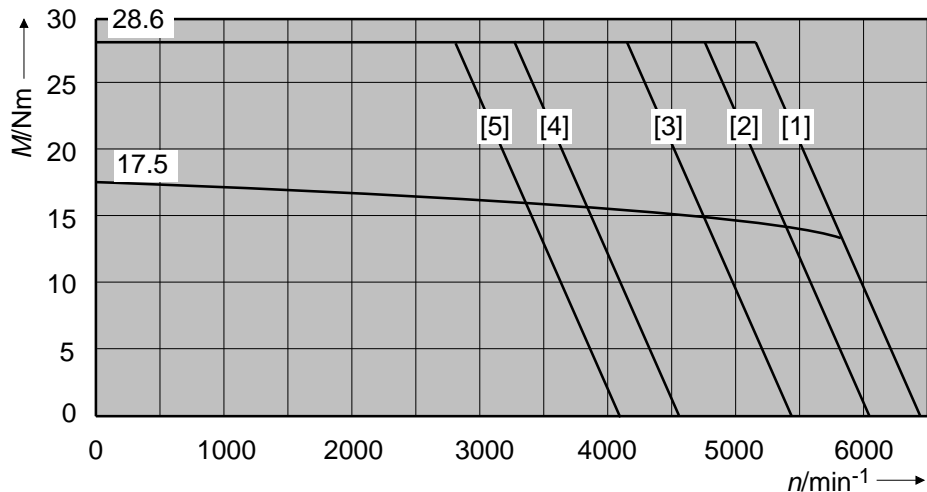
MDD 093A-F
with 4000 min⁻¹



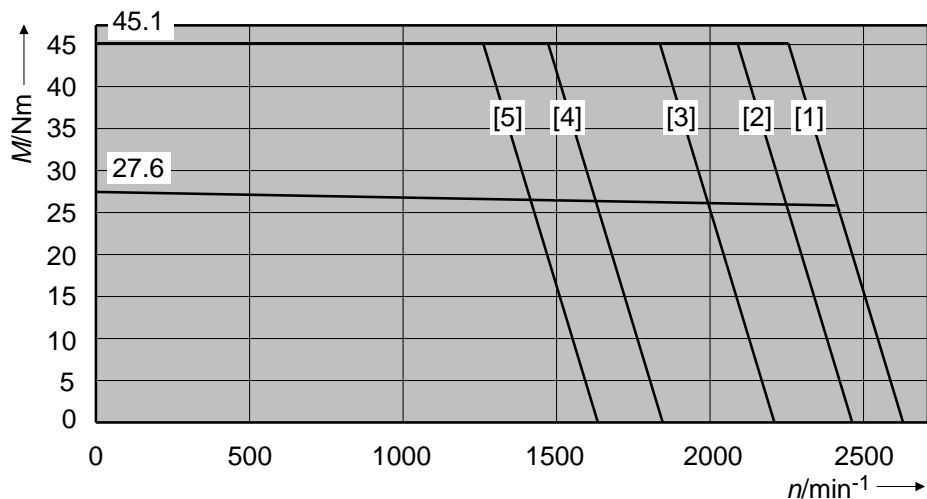
DGMDD093A

Figure 3.16: Torque-speed characteristics curves for MDD 093A

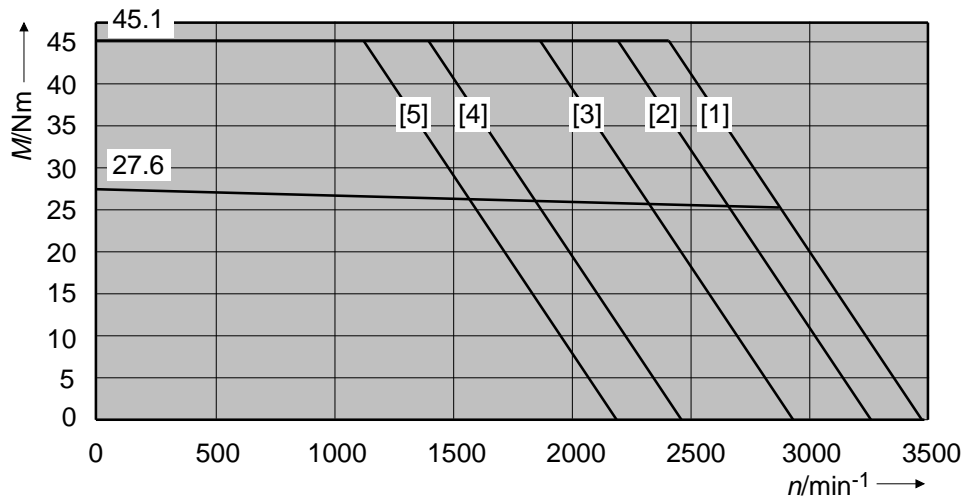
MDD 093A-F
with 6000 min⁻¹



MDD 093B-F
with 2000 min⁻¹



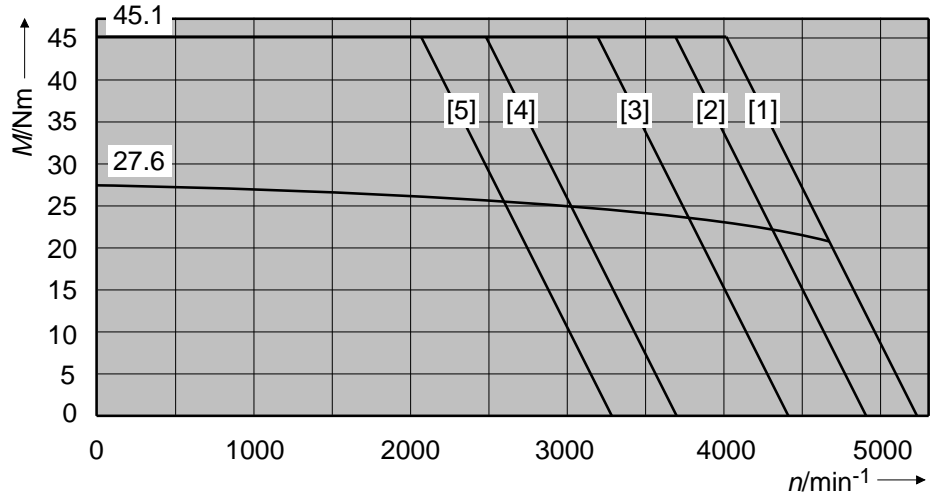
MDD 093B-F
with 3000 min⁻¹



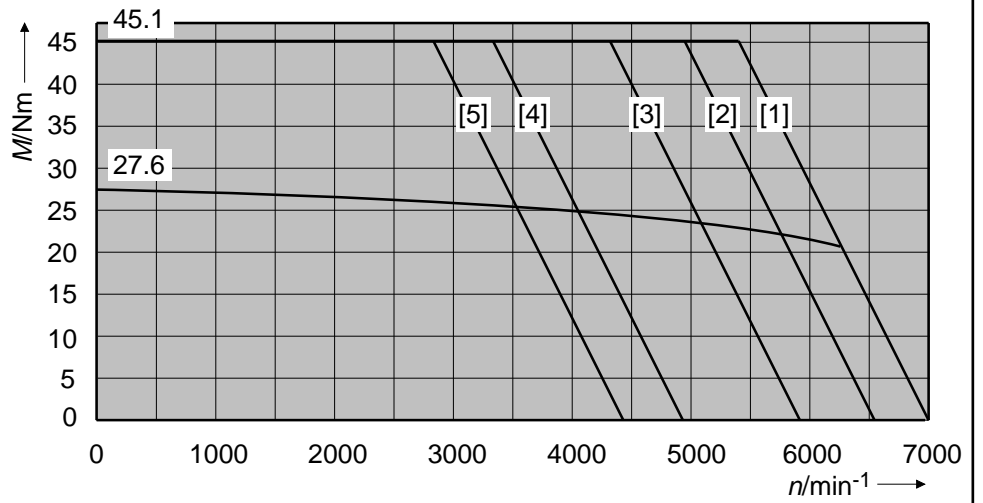
DGMDD093AB

Figure 3.17: Torque-speed characteristics curves for MDD 093A and MDD 093B

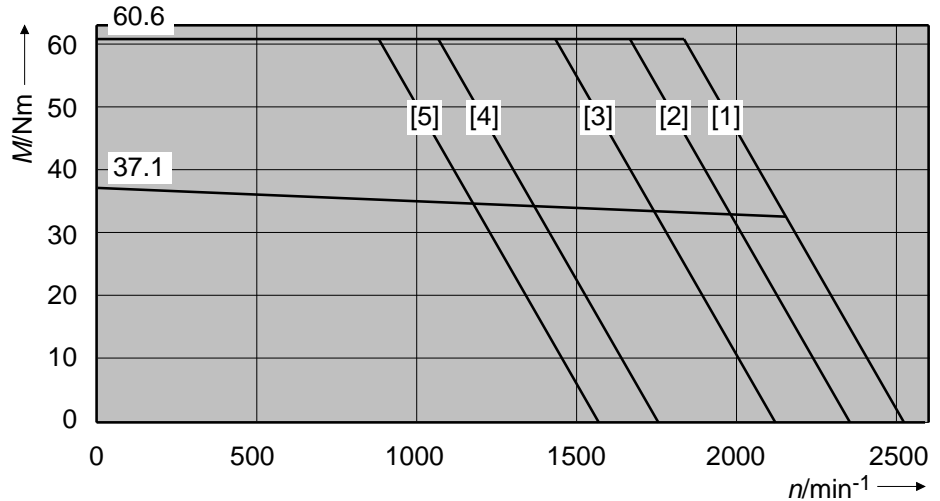
*MDD 093B-F
with 4000 min⁻¹*



*MDD 093B-F
with 6000 min⁻¹*



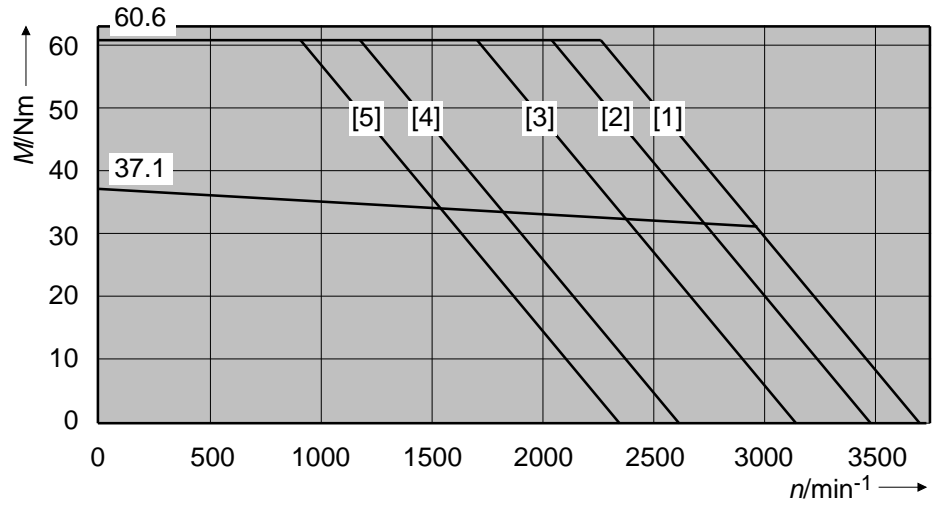
*MDD 093C-F
with 2000 min⁻¹*



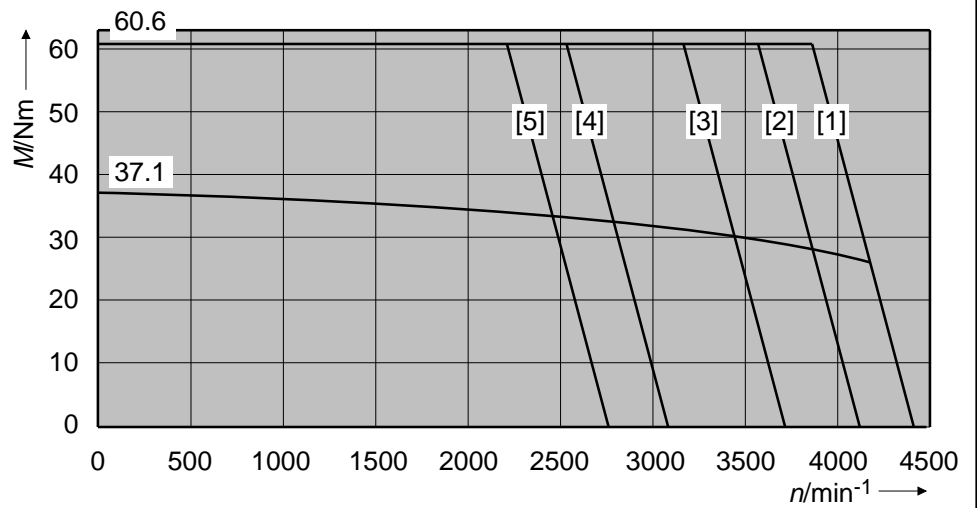
DGMDD093BC

Figure 3.18: Torque-speed characteristics curves for MDD 093B and MDD 093

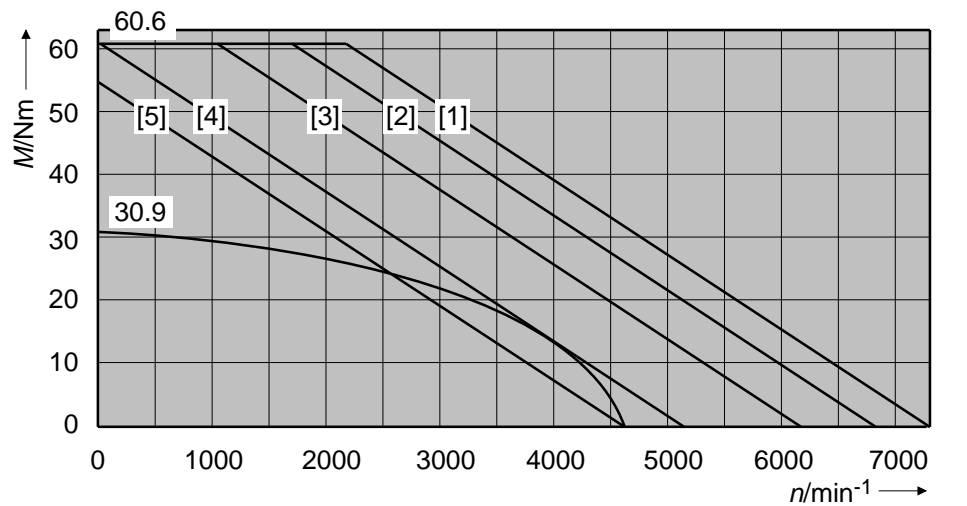
*MDD 093C-F
with 3000 min⁻¹*



*MDD 093C-F
with 4000 min⁻¹*



*MDD 093C-F
with 6000 min⁻¹*



DGMDD093C

Figure 3.19: Torque-speed characteristics curves for MDD 093C

*MDD 093D-F
with 1500 min⁻¹*

*MDD 093D-F
with 2000 min⁻¹*

*MDD 093D-F
with 3000 min⁻¹*

in preparation

Figure 3.20: Torque-speed characteristics curves for MDD 093D

*MDD 093D-F
with 4000 min⁻¹*

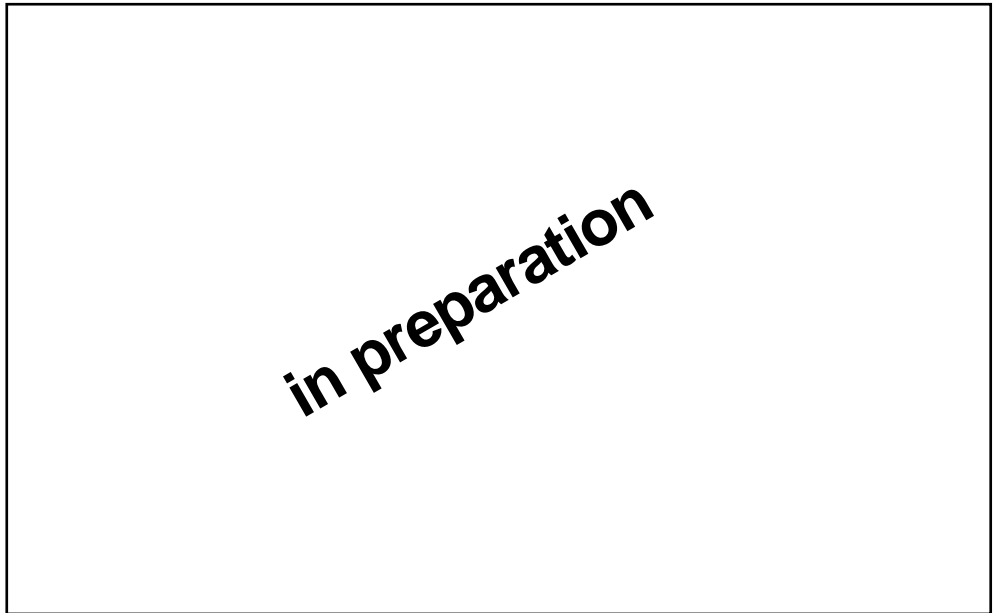


Figure 3.21: Torque-speed characteristics curves for MDD 093D

3.2.3. MDD 093 - shaft load

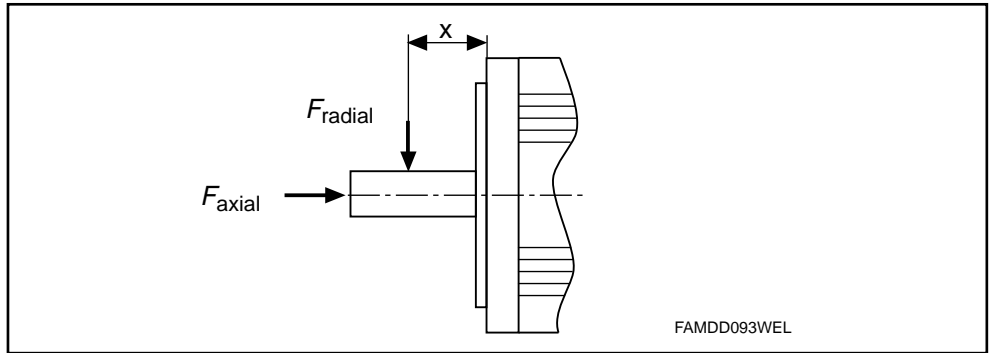


Figure 3.22: Shaft load

Radial force F_{radial}

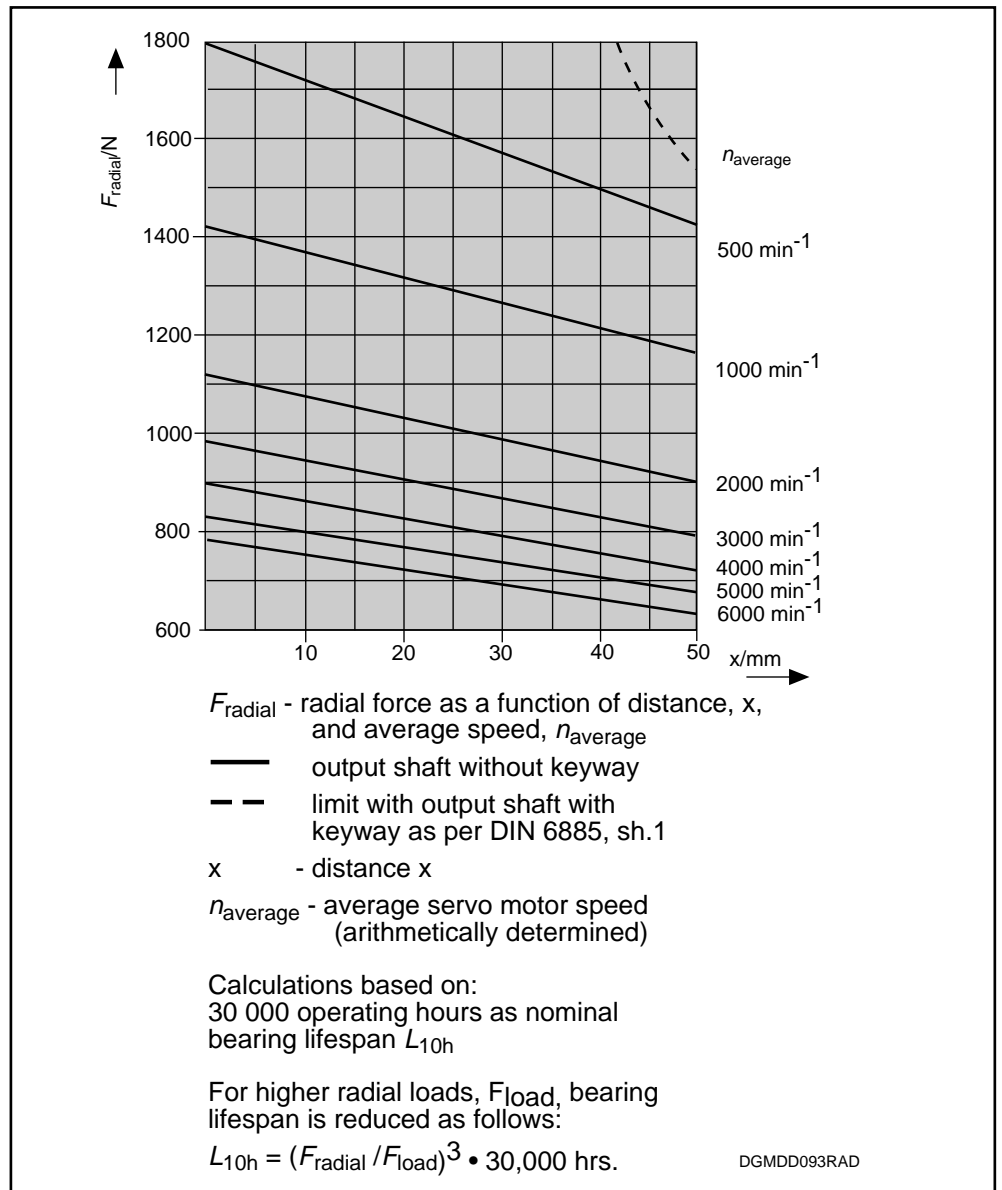


Figure 3.23: Radial force

Axial force F_{axial}

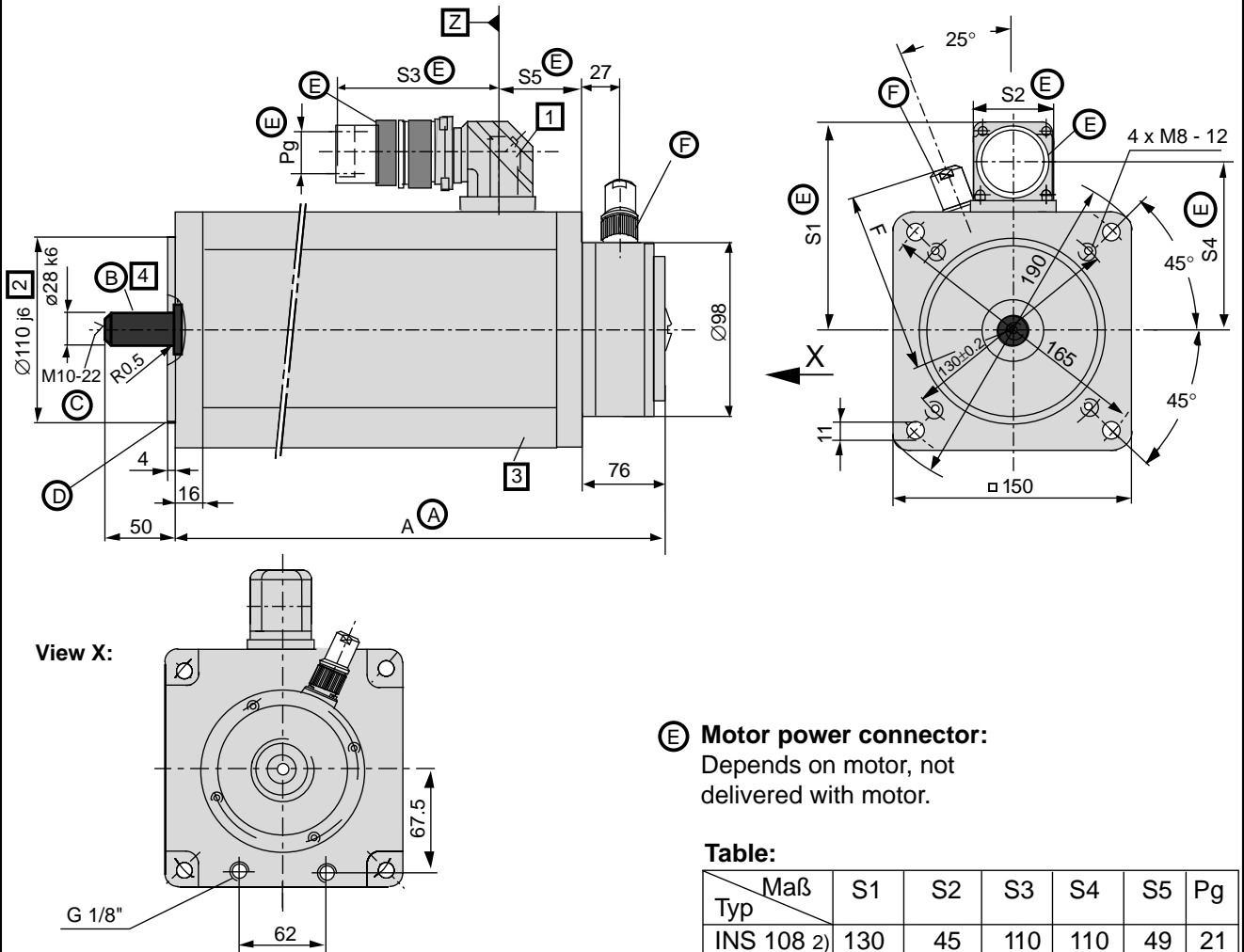
$$F_{axial} = 0.34 \cdot F_{radial}$$

F_{axial} - permissible axial force

F_{radial} - permissible radial force

3.2.4. MDD 093 - dimensional data

General dimensions:



View X:

E Motor power connector:
Depends on motor, not delivered with motor.

Table:

Typ	Maß	S1	S2	S3	S4	S5	Pg
INS 108 2)		130	45	110	110	49	21
INS 172		137	52	145	112	55,5	36

2) for MDD 093 A - F - 020,
MDD 093 B - F - 020,
MDD 093 A - F - 030,

A Table:

Size	Dim. A 1)
MDD 093 A	286
MDD 093 B	327
MDD 093 C	386
MDD 093 D	436

1) Larger with some options.
The applicable dimensions are given with the option.

B Position accuracy as per tolerance R DIN 42 955

C center drill hole DS M10 per DIN 332, sh. 2

D Flange type determines mounting mode

- as per design B5 (drill hole in flange)
- as per design B14 (windings in flange)

F Feedback connector:
Not delivered with motor.

Table:

Name	Connector	Dim. F
straight	INS 513	110
	INS 512	112
elbow	INS 511	108
	INS 510	

MBMDD093A

Figure 3.24: General data on MDD 093 (liquid-cooled)

Options-dependent dimensions:

1 Mounting direction of motor power connector:

- to side A
 - to side B
 - to the right
 - to the left
- } looking towards motor shaft

Side A is depicted as the output direction in the drawing. The dimensions of other output directions can be obtained by turning the housing around the Z axis.

2 Custom centering diameter:

- $\varnothing 130\ j6$

3 Holding brake:

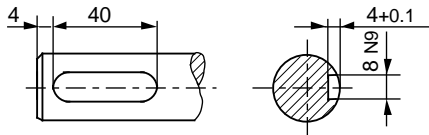
- Holding torque of 11 Nm
- Holding torque of 22 Nm

Table for holding torque of 11 Nm
does not affect outer dimensions

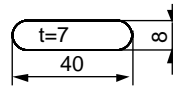
Table for holding torque of 22 Nm	
Size	Dim. A
MDD 093 A	316
MDD 093 B	357
MDD 093 C	416
MDD 093 D	466

4 Output shaft:

- plain shaft (preferred type)
- with keyway as per DIN 6885, sh. 1 (Note: balanced with entire key!)



matching key: DIN 6885-A 8x7x40



MBMDD0930

Figure 3.25: Options-dependent dimensions for MDD 093 (liquid-cooled)

3.2.5. MDD 093 - type codes

Type codes:	Example:	M	D	D	0	9	3	B	-	F	-	0	2	0	-	N	2	L	-	1	1	0	G	B	0	/	S	0	0	0
1. Designation Motor for digital drives	MDD																													
2. Motor size	093																													
3. Motor length	A, B, C, D																													
4. Housing: for liquid-cooling	F																													
5. Rated speed 1500 min ⁻¹ 2000 min ⁻¹ 3000 min ⁻¹ 4000 min ⁻¹ 6000 min ⁻¹	015 ¹⁾ 020 030 040 060 ²⁾																													
6. Balance class N per DIN ISO 2373 R per DIN ISO 2373	N R																													
7. Shaft end on side B Standard (without second shaft end)	2																													
8. Motor feedback digital servo feedback digital servo feedback with integrated multiturn encoder	L M																													
9. Centering diameter ø110 mm ø130 mm	110 130																													
10. Output shaft plain shaft shaft with keyway per DIN 6885, sheet 1	G P																													
11. Output direction of power connection To side A To side B To the right (looking towards shaft, housing on top) To the left (looking towards shaft, housing on top)	R L																													
12. Holding brake no holding brake with holding brake of 11.0 Nm with holding brake of 22.0 Nm	0 1 2																													
13. Custom version Fixed and documented by INDRAMAT with custom number. Field 13 does not apply to standard motors																														

¹⁾ only for motor length "D"
²⁾ not for motor length "D"

Figure 3.26: Options for MDD 093 (liquid-cooled)

3.3. MDD 112 (liquid-cooled)

3.3.1. MDD 112 - motor data

Designation	Symbol	Unit				
			112A-F-015	112A-F-020	112A-F-030	112A-F-040
Motor type MDD . . .						
Basic motor speed ¹⁾	n	min ⁻¹	1500	2000	3000	4000
Continuous stall torque	M_{dN}	Nm	19.6	19.6	19.6	19.6
Continuous stall current	I_{dN}	A	15.6	22.0	32.1	42.6
Theor. maximum speed ²⁾	M_{max}	Nm	31.4	30.8	31.5	31.3
Peak current	I_{max}	A	26.7	37.0	55.3	72.9
Rotor inertia ³⁾	J_M	kgm ²	0.0061	0.0061	0.0061	0.0061
Torque constant at 20 °C	K_m	Nm/A	1.26	0.89	0.61	0.46
Windings resistance at 20 °C	R_A	Ohm	2.94	1.40	0.66	0.38
Windings inductance	L_A	mH	33	17	6.8	4.0
Thermal time constant	T_{th}	min	50	50	50	50
Mass ³⁾	m_M	kg	25	25	25	25
Rated power loss	P_{vN}	W	720			
Ambient temperature ⁴⁾	ϑ_{amb}	°C	+5° to +45°			
Coolant entry temperature	ϑ_{ein}	°C	+10° to +40°			
Coolant temperature increase with P_{vN}	$\Delta\vartheta_N$	°C	10			
Minimum coolant flow through with $\Delta\vartheta_N$ ⁵⁾	Q_N	l/min	1.0			
Pressure drop with Q_N ^{5) 6)}	Δp_N	bar	0.5			
Maximum system pressure	p_{max}	bar	3			
Volume in coolant canal	V	l				
Storage and transportation temperature ⁷⁾	ϑ_L	°C	-20° to +80°			
Maximum installation altitude		m	1000 meters above sea level			
Protection category			IP 65			
Insulation classification			F			
Housing finish			prime coat black (RAL 9005)			
<u>options</u> <u>holding brake, electrical release</u>						
Holding torque	M_H	Nm	14			
Rated voltage	U_N	V	24 ± 10%			
Rated current	I_N	A	0.75			
Inertia	J_B	kgm ²	3.6 x 10 ⁻⁴			
Release delay	t_L	ms	70			
Clamping delay	t_K	ms	30			
Mass	m_B	kg	1.1			
<p>¹⁾ Usable motor speed is determined by the torque requirements of the application. The usable speeds n_{max} found in the selection lists of the motor-drive combinations are binding for standard applications. The usable speeds for other applications can be found using the required torque in the torque-speed characteristics curves.</p> <p>²⁾ The maximum achievable torque depends upon the drive used. Only those maximum torques M_{max} found in the selection list of the motor-drive combinations are binding.</p> <p>³⁾ Without holding brake.</p> <p>⁴⁾ Note the relationship between the actual ϑ_{amb} and the ϑ_{ein}: ϑ_{ein} may be no more than 5 °C below ϑ_{amb}!</p> <p>⁵⁾ With coolant water.</p> <p>⁶⁾ Note flow diagram for deviating flow values.</p> <p>⁷⁾ Empty of all coolant prior to transportation or storage.</p>						

Figure 3.27: Technical data for MDD 112A (liquid-cooled)

3. Technical data

Designation	Symbol	Unit				
			112B-F-015	112B-F-020	112B-F-030	112B-F-040
Motor type MDD . . .						
Basic motor speed ¹⁾	n	min ⁻¹	1500	2000	3000	4000
Continuous stall torque	M_{dN}	Nm	32.7	32.7	32.7	32.7
Continuous stall current	I_{dN}	A	27.7	38.9	52.7	77.4
Theor. maximum speed ²⁾	M_{max}	Nm	61.0	64.8	64.0	65.3
Peak current	I_{max}	A	55.3	82.6	111	166
Rotor inertia ³⁾	J_M	kgm ²	0.012	0.012	0.012	0.012
Torque constant at 20 °C	K_m	Nm/A	1.18	0.84	0.62	0.42
Windings resistance at 20 °C	R_A	Ohm	0.85	0.43	0.25	0.11
Windings inductance	L_A	mH	15	5.7	3.1	2.0
Thermal time constant	T_{th}	min	50	50	50	50
Mass ³⁾	m_M	kg	36	36	36	36
Rated power loss	P_{vN}	W	680			
Ambient temperature ⁴⁾	ϑ_{amb}	°C	+5° to +45°			
Coolant entry temperature	ϑ_{ein}	°C	+10° to +40°			
Coolant temperature increase with P_{vN}	$\Delta\vartheta_N$	°C	10			
Minimum coolant flow through with $\Delta\vartheta_N$ ⁵⁾	Q_N	l/min	1.0			
Pressure drop with Q_N ^{5) 6)}	Δp_N	bar	0.5			
Maximum system pressure	p_{max}	bar	3			
Volume in coolant canal	V	l				
Storage and transportation temperature ⁷⁾	ϑ_L	°C	-20° to +80°			
Maximum installation altitude		m	1000 meters above sea level			
Protection category			IP 65			
Insulation classification			F			
Housing finish			prime coat black (RAL 9005)			
<u>options</u> <u>holding brake, electrical release</u>						
Holding torque	M_H	Nm	14	40	60	
Rated voltage	U_N	V	24 ± 10%	24 ± 10%	24 ± 10%	
Rated current	I_N	A	0.75	1.35	1.35	
Inertia	J_B	kgm ²	3.6 x 10 ⁻⁴	32 x 10 ⁻⁴	32 x 10 ⁻⁴	
Release delay	t_L	ms	70	150	150	
Clamping delay	t_K	ms	30	30	30	
Mass	m_B	kg	1.1	3.5	3.5	
<p>¹⁾ Usable motor speed is determined by the torque requirements of the application. The usable speeds n_{max} found in the selection lists of the motor-drive combinations are binding for standard applications. The usable speeds for other applications can be found using the required torque in the torque-speed characteristics curves.</p> <p>²⁾ The maximum achievable torque depends upon the drive used. Only those maximum torques M_{max} found in the selection list of the motor-drive combinations are binding.</p> <p>³⁾ Without holding brake.</p> <p>⁴⁾ Note the relationship between the actual ϑ_{amb} and the ϑ_{ein}: ϑ_{ein} may be no more than 5 °C below ϑ_{amb}!</p> <p>⁵⁾ With coolant water.</p> <p>⁶⁾ Note flow diagram for deviating flow values.</p> <p>⁷⁾ Empty of all coolant prior to transportation or storage.</p>						

Figure 3.28: Technical data for MDD 112B (liquid-cooled)

3. Technical data

Designation	Symbol	Unit				
Motor type MDD . . .			112C-F-015	112C-F-020	112C-F-030	112C-F-040
Basic motor speed ¹⁾	n	min ⁻¹	1500	2000	3000	4000
Continuous stall torque	M_{dN}	Nm	52.3	52.3	52.3	49.4
Continuous stall current	I_{dN}	A	41.5	55.6	80.5	102.9
Theor. maximum speed ²⁾	M_{max}	Nm	97.3	97.1	101	99.7
Peak current	I_{max}	A	82.6	111	166	222
Rotor inertia ³⁾	J_M	kgm ²	0.017	0.017	0.017	0.017
Torque constant at 20 °C	K_m	Nm/A	1.26	0.94	0.65	0.48
Windings resistance at 20 °C	R_A	Ohm	0.56	0.31	0.14	0.08
Windings inductance	L_A	mH	7.9	5.0	2.0	1.5
Thermal time constant	T_{th}	min	50	50	50	50
Mass ³⁾	m_M	kg	48	48	48	48
Rated power loss	P_{vN}	W	980			
Ambient temperature ⁴⁾	ϑ_{amb}	°C	+5° to +45°			
Coolant entry temperature	ϑ_{ein}	°C	+10° to +40°			
Coolant temperature increase with P_{vN}	$\Delta\vartheta_N$	°C	10			
Minimum coolant flow through with $\Delta\vartheta_N$ ⁵⁾	Q_N	l/min	1.4			
Pressure drop with Q_N ^{5) 6)}	Δp_N	bar	0.7			
Maximum system pressure	p_{max}	bar	3			
Volume in coolant canal	V	l				
Storage and transportation temperature ⁷⁾	ϑ_L	°C	-20° to +80°			
Maximum installation altitude		m	1000 meters above sea level			
Protection category			IP 65			
Insulation classification			F			
Housing finish			prime coat black (RAL 9005)			
<u>options</u>						
<u>holding brake, electrical release</u>						
Holding torque	M_H	Nm	14	40	60	
Rated voltage	U_N	V	24 ± 10%	24 ± 10%	24 ± 10%	
Rated current	I_N	A	0.75	1.35	1.35	
Inertia	J_B	kgm ²	3.6 x 10 ⁻⁴	32 x 10 ⁻⁴	32 x 10 ⁻⁴	
Release delay	t_L	ms	70	150	150	
Clamping delay	t_K	ms	30	30	30	
Mass	m_B	kg	1.1	3.5	3.5	
<p>1) Usable motor speed is determined by the torque requirements of the application. The usable speeds n_{max} found in the selection lists of the motor-drive combinations are binding for standard applications. The usable speeds for other applications can be found using the required torque in the torque-speed characteristics curves.</p> <p>2) The maximum achievable torque depends upon the drive used. Only those maximum torques M_{max} found in the selection list of the motor-drive combinations are binding.</p> <p>3) Without holding brake.</p> <p>4) Note the relationship between the actual ϑ_{amb} and the ϑ_{ein}: ϑ_{ein} may be no more than 5 °C below ϑ_{amb}!</p> <p>5) With coolant water.</p> <p>6) Note flow diagram for deviating flow values.</p> <p>7) Empty of all coolant prior to transportation or storage.</p>						

Figure 3.29: Technical data for MDD 112C (liquid-cooled)

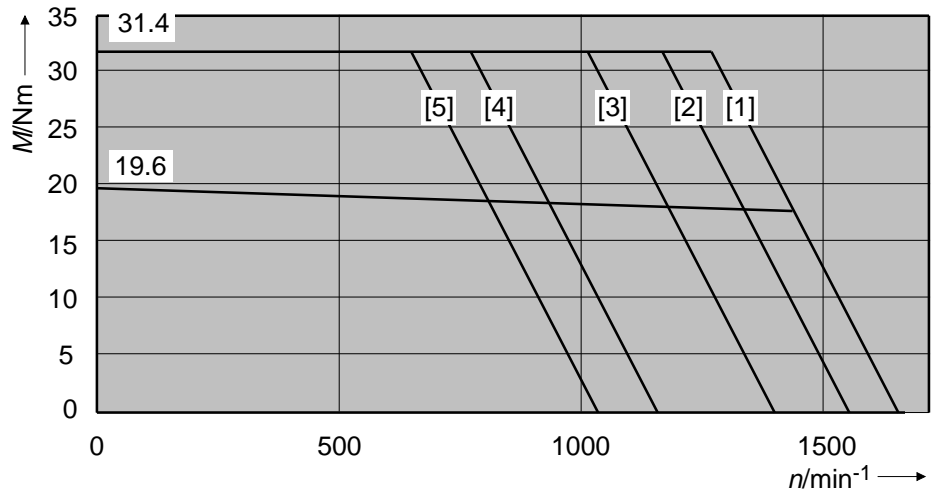
3. Technical data

Designation	Symbol	Unit				
Motor type MDD . . .			112D-F-015	112D-F-020	112D-F-030	112D-F-040
Basic motor speed ¹⁾	n	min ⁻¹	1500	2000	3000	4000
Continuous stall torque	M_{dN}	Nm	71.0	71.0	64.8	44.2
Continuous stall current	I_{dN}	A	55.5	81.6	102.9	102.9
Theor. maximum speed ²⁾	M_{max}	Nm	132	135	131	132
Peak current	I_{max}	A	111	166	222	329
Rotor inertia ³⁾	J_M	kgm ²	0.023	0.023	0.023	0.023
Torque constant at 20 °C	K_m	Nm/A	1.28	0.87	0.63	0.43
Windings resistance at 20 °C	R_A	Ohm	0.39	0.18	0.10	0.05
Windings inductance	L_A	mH	5,9	2,7	1,5	1,0
Thermal time constant	T_{th}	min	60	60	60	60
Mass ³⁾	m_M	kg	59	59	59	59
Rated power loss	P_{vN}	W	1240			
Ambient temperature ⁴⁾	ϑ_{amb}	°C	+5° to +45°			
Coolant entry temperature	ϑ_{ein}	°C	+10° to +40°			
Coolant temperature increase with P_{vN}	$\Delta\vartheta_N$	°C	10			
Minimum coolant flow through with $\Delta\vartheta_N$ ⁵⁾	Q_N	l/min	1.8			
Pressure drop with Q_N ^{5) 6)}	Δp_N	bar	1.0			
Maximum system pressure	p_{max}	bar	3			
Volume in coolant canal	V	l				
Storage and transportation temperature ⁷⁾	ϑ_L	°C	-20° to +80°			
Maximum installation altitude		m	1000 meters above sea level			
Protection category			IP 65			
Insulation classification			F			
Housing finish			prime coat black (RAL 9005)			
<u>options</u>						
<u>holding brake, electrical release</u>						
Holding torque	M_H	Nm	14	40	60	
Rated voltage	U_N	V	24 ± 10%		24 ± 10%	
Rated current	I_N	A	0.75	1.35	1.35	
Inertia	J_B	kgm ²	3.6 x 10 ⁻⁴	32 x 10 ⁻⁴		32 x 10 ⁻⁴
Release delay	t_L	ms	70	150	150	
Clamping delay	t_K	ms	30	30	30	
Mass	m_B	kg	1.1	3.5		3.5
<p>) Usable motor speed is determined by the torque requirements of the application. The usable speeds n_{max} found in the selection lists of the motor-drive combinations are binding for standard applications. The usable speeds for other applications can be found using the required torque in the torque-speed characteristics curves.</p> <p>2) The maximum achievable torque depends upon the drive used. Only those maximum torques M_{max} found in the selection list of the motor-drive combinations are binding.</p> <p>3) Without holding brake.</p> <p>4) Note the relationship between the actual ϑ_{amb} and the ϑ_{ein}: ϑ_{ein} may be no more than 5 °C below ϑ_{amb}!</p> <p>5) With coolant water.</p> <p>6) Note flow diagram for deviating flow values.</p> <p>7) Empty of all coolant prior to transportation or storage.</p>						

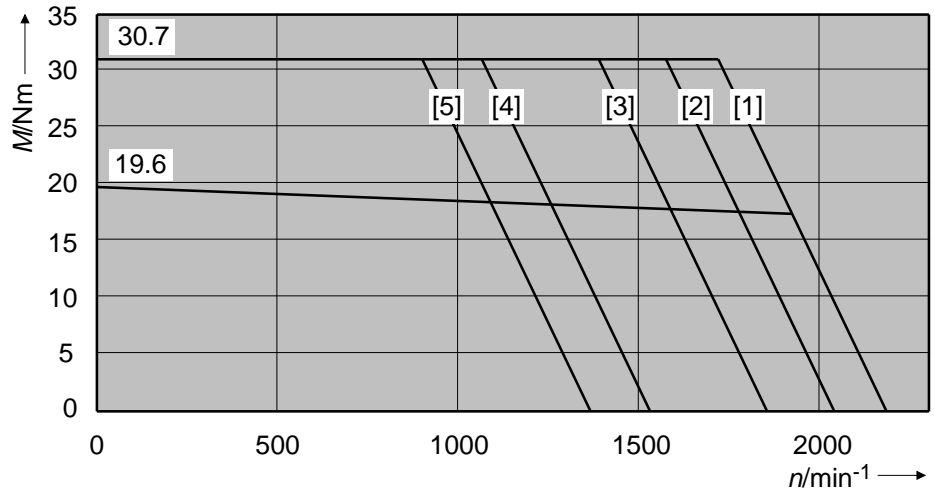
Figure 3.30: Technical data for MDD 112D (liquid-cooled)

3.3.2. Torque-speed characteristics curves for MDD 112

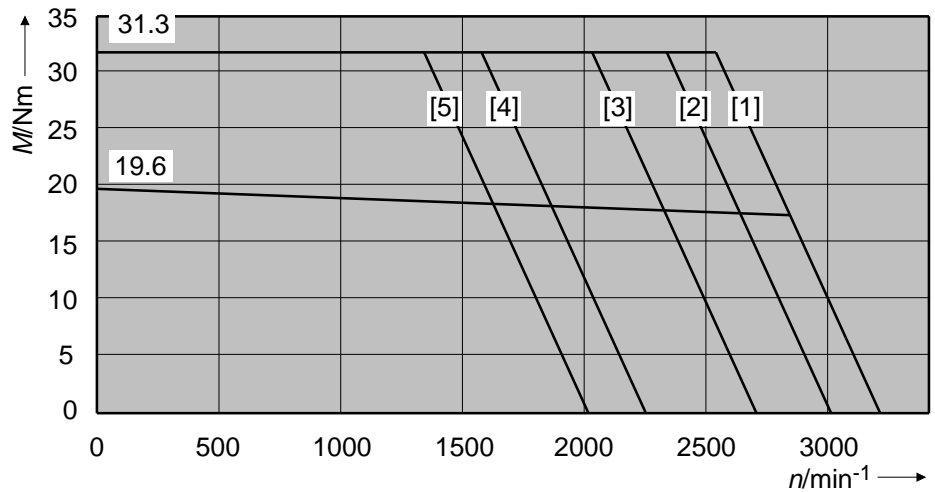
MDD 112A-F
with 1500 min⁻¹



MDD 112A-F
with 2000 min⁻¹



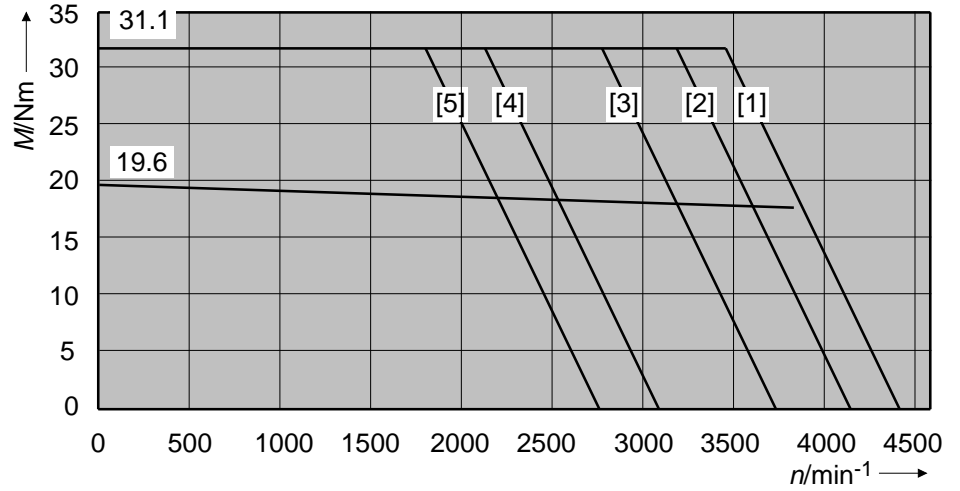
MDD 112A-F
with 3000 min⁻¹



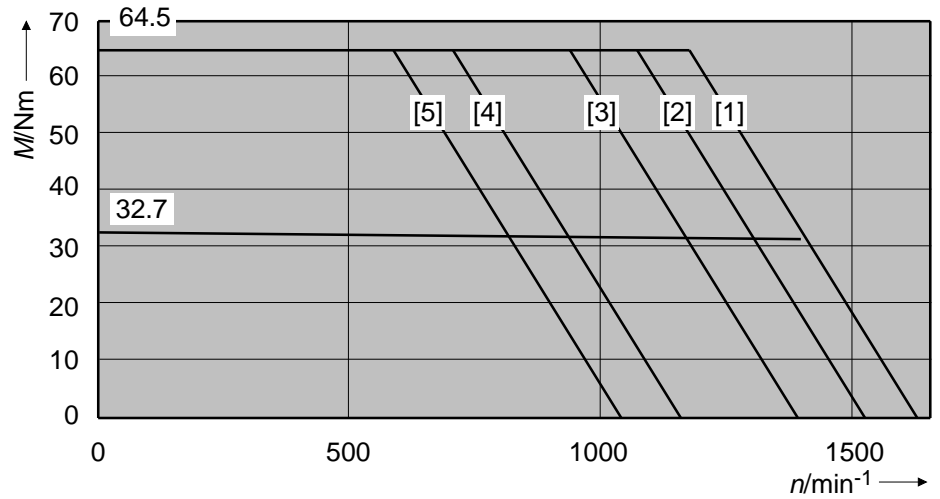
DGMDD112A

Figure 3.31: Torque-speed characteristics curves for MDD 112A

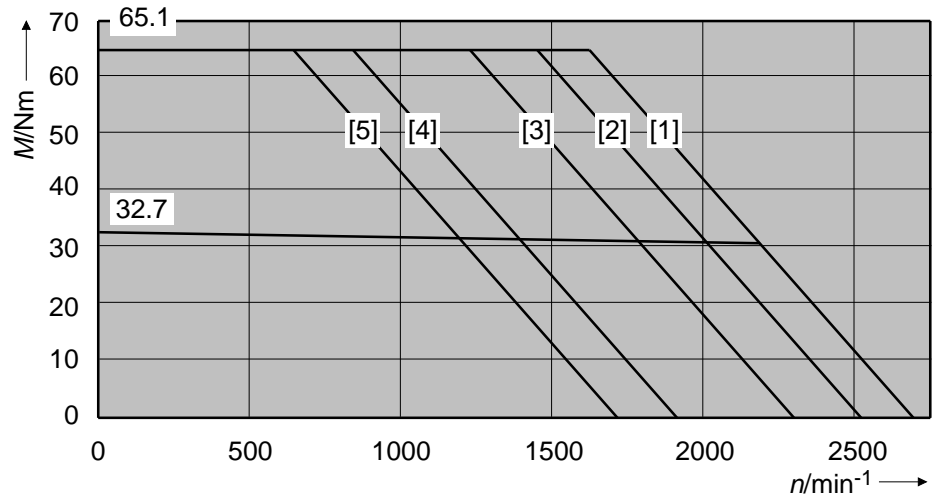
MDD 112A-F
with 4000 min⁻¹



MDD 112B-F
with 1500 min⁻¹



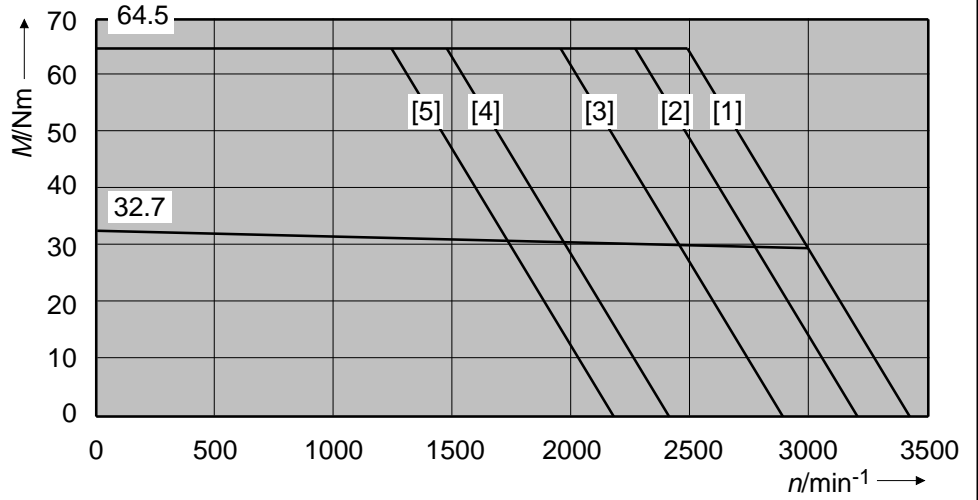
MDD 112B-F
with 2000 min⁻¹



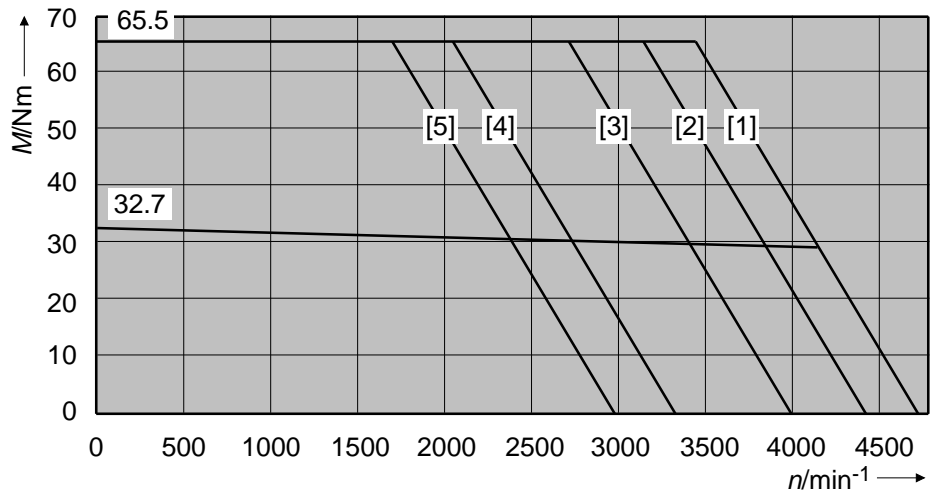
DGMDD112AB

Figure 3.32: Torque-speed characteristics curves for MDD 112A und MDD 112B

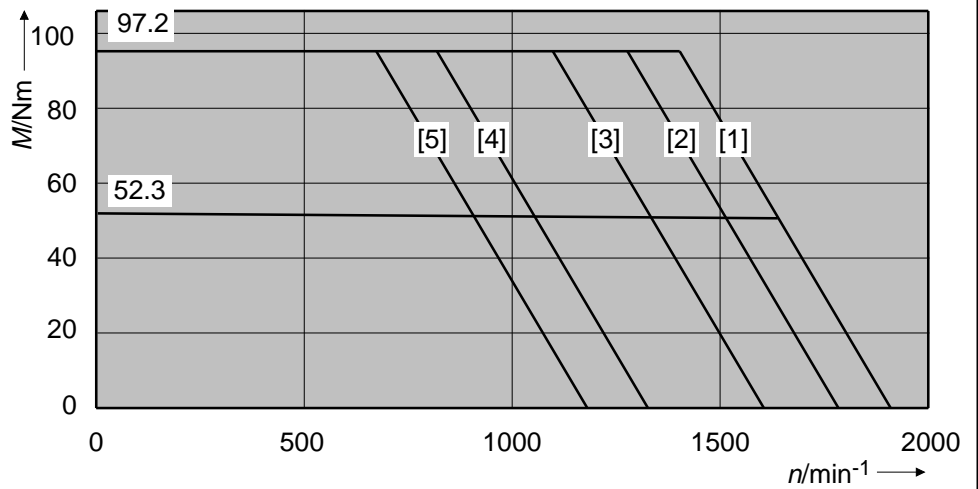
*MDD 112B-F
with 3000 min⁻¹*



*MDD 112B-F
with 4000 min⁻¹*



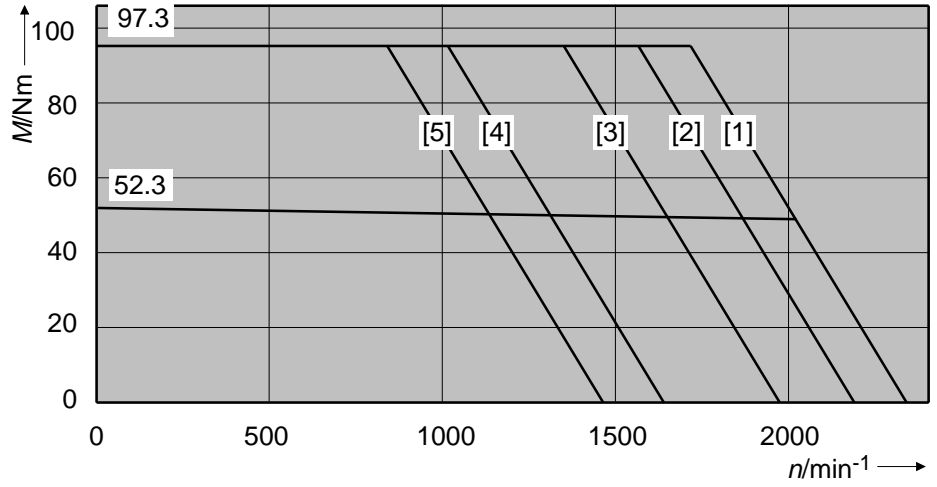
*MDD 112C-F
with 1500 min⁻¹*



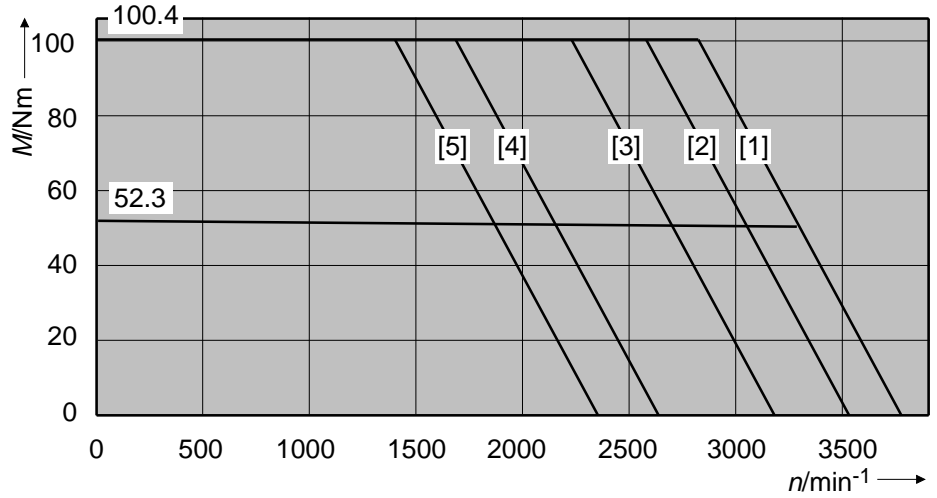
DGMDD112BC

Figure 3.33: Torque-speed characteristics curves for MDD 112B und MDD 112C

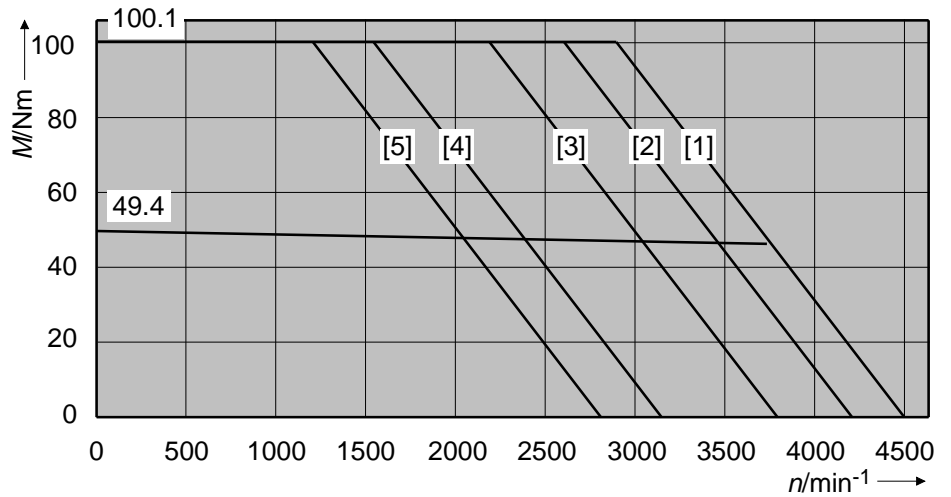
*MDD 112C-F
with 2000 min⁻¹*



*MDD 112C-F
with 3000 min⁻¹*



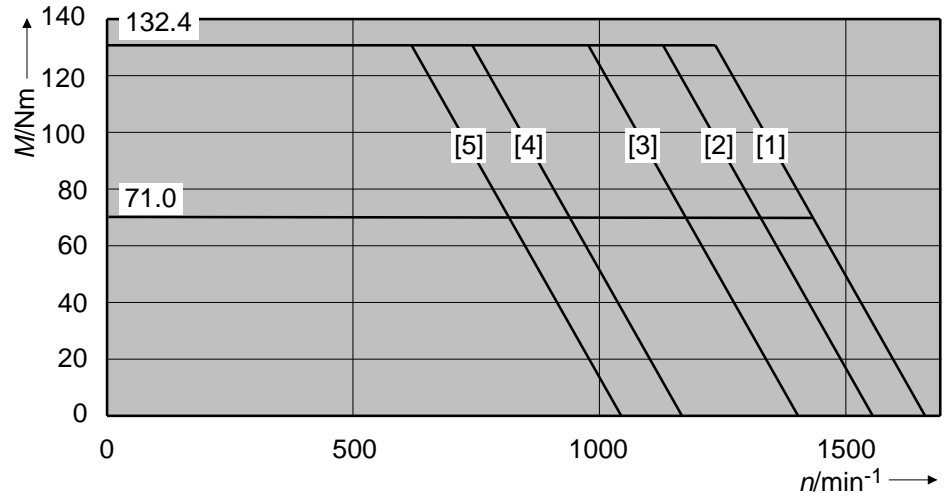
*MDD 112C-F
with 4000 min⁻¹*



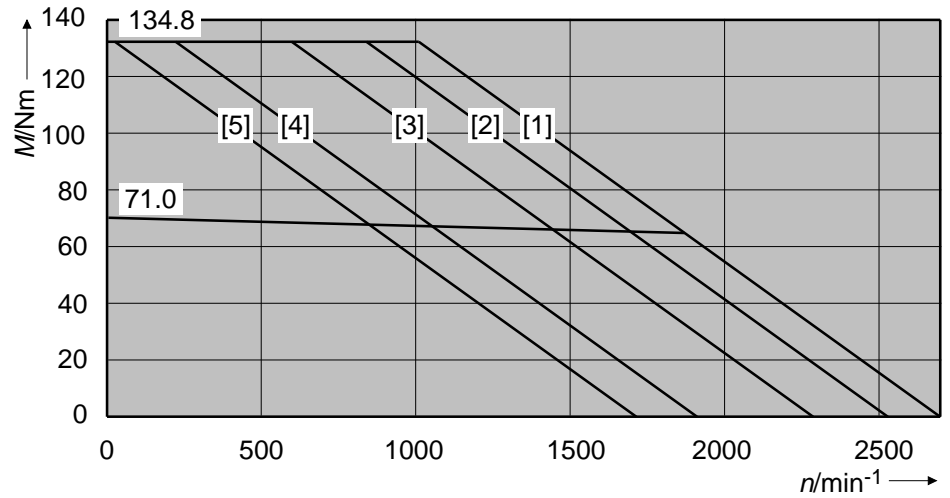
DGMDD112C

Figure 3.34: Torque-speed characteristics curves for MDD 112C

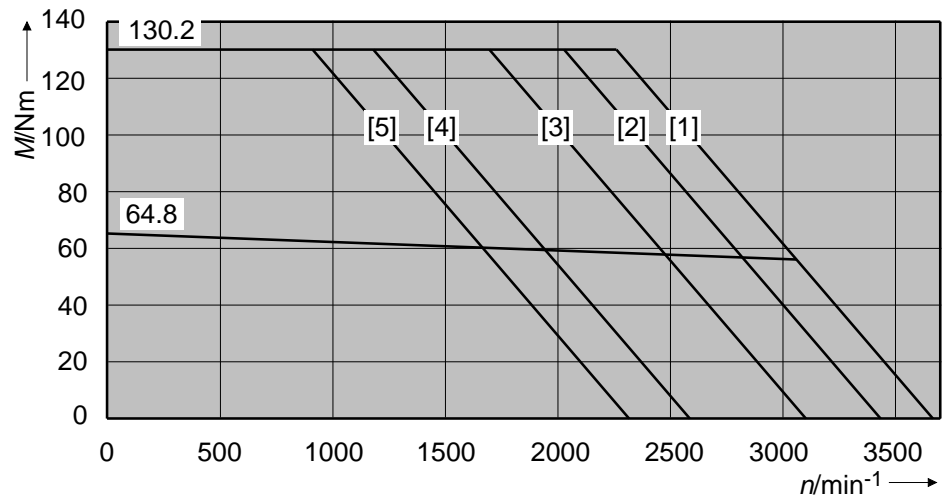
*MDD 112D-F
with 1500 min⁻¹*



*MDD 112D-F
with 2000 min⁻¹*



*MDD 112D-F
with 3000 min⁻¹*



DGMDD112D

Figure 3.35: Torque-speed characteristics curves for MDD 112D

*MDD 112D-F
with 4000 min⁻¹*

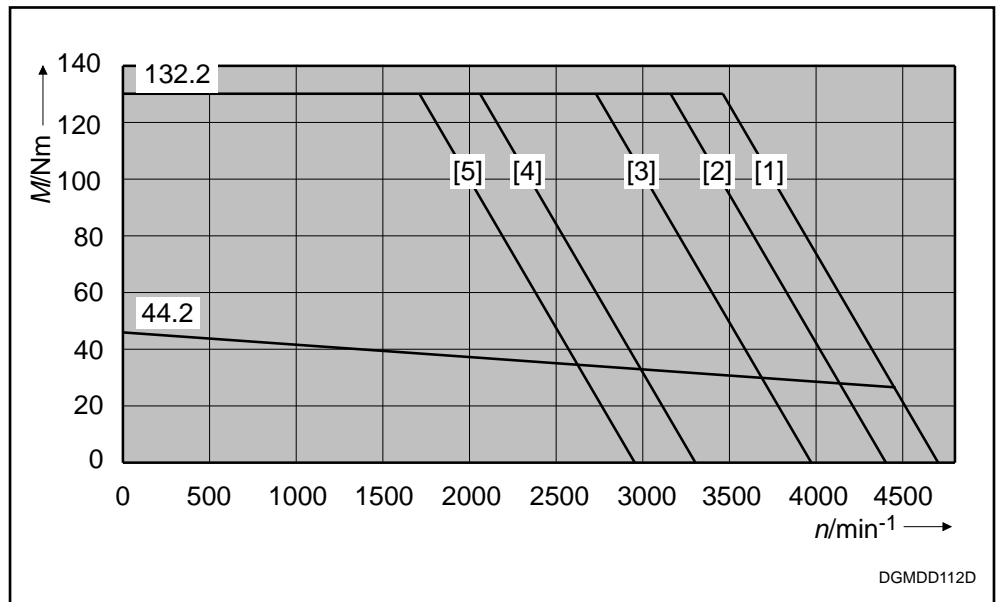


Figure 3.36: Torque-speed characteristics curves for MDD 112D

3.3.3 MDD 112 - shaft load

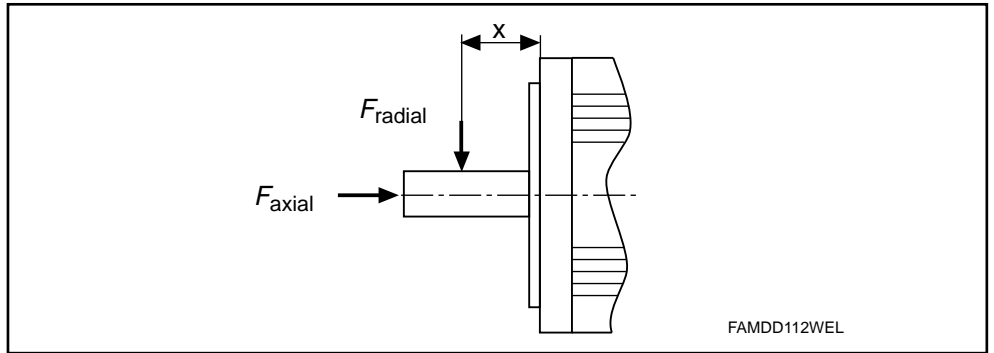


Figure 3.37: Shaft load

Radial force F_{radial}

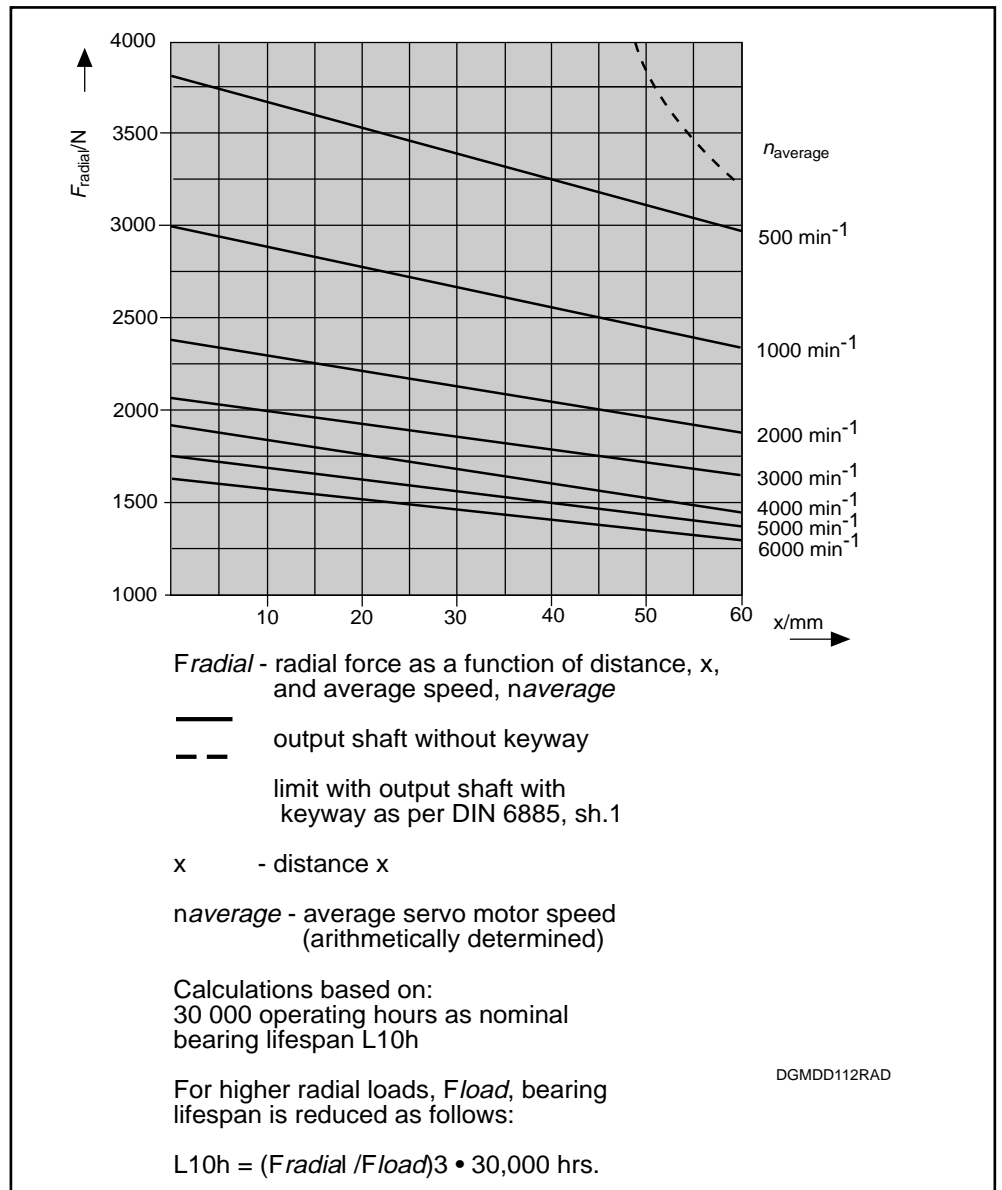


Figure 3.38: Radial force

Axial force F_{axial}

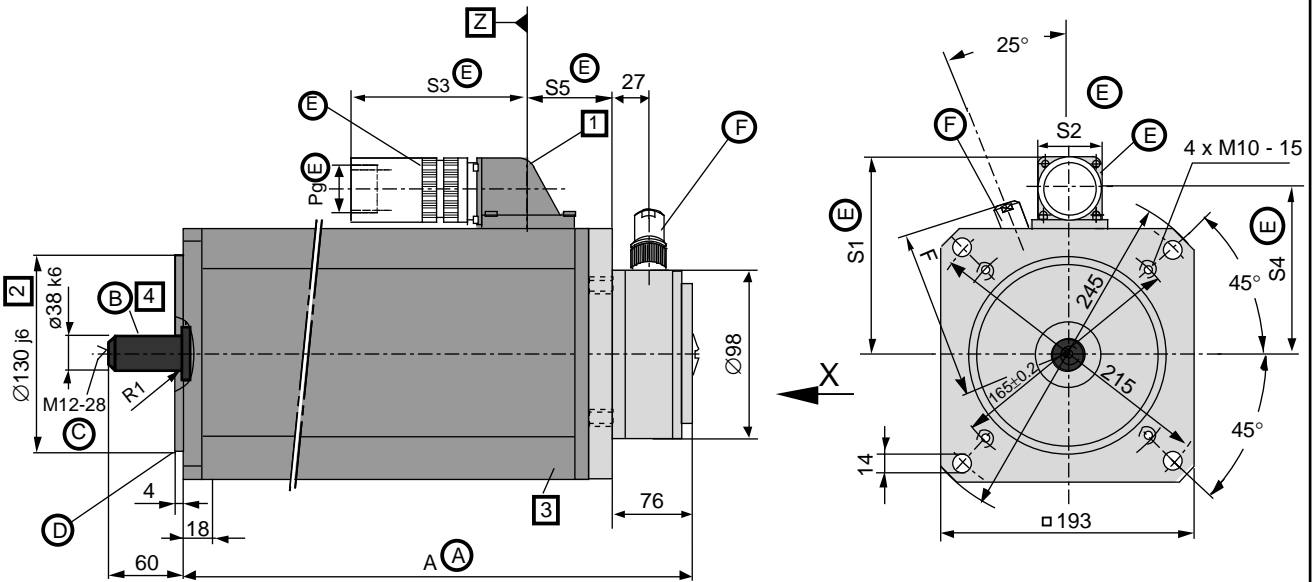
$$F_{axial} = 0.35 \cdot F_{radial}$$

F_{axial} - permissible axial force

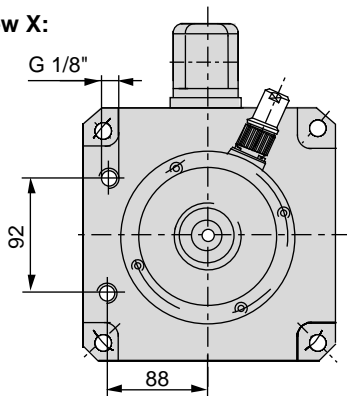
F_{radial} - permissible radial force

3.3.4. MDD 112 - dimensional data

General dimensions:



View X:



(A) Table:

Size	Dim.A 1)
MDD 112 A	312
MDD 112 B	387
MDD 112 C	462
MDD 112 D	537

1) Larger with some options.
The applicable dimension is given with the option.

(B) position accuracy per tolerance R DIN 42 955

(C) center drill hole DS M12 per DIN 332 sh. 2

(D) flange determines mounting mode

- per design B5 (drill hole in flange)
- per design B14 (windings in flange)

(E) Motor power connector:

Depends on motor, not delivered with motor.

Table:

Dim. Type	S1	S2	S3	S4	S5 1)	Pg
INS 108 2)	151	45	110	133	56	21
INS 172	160	52	145	137	62,5	36

2) for MDD 112 A - F - 015
MDD 112 B - F - 015
MDD 112 A - F - 020
MDD 112 A - F - 030

(F) Feedback connector:

Not delivered with motor

Table:

Name	Connector	Dim. F
straight	INS 513	110
	INS 512	112
elbow	INS 511	108
	INS 510	

MBMDD112A

Figure 3.39: General data on MDD 112 (liquid-cooled)

Option-dependent dimensions:

1 Mounting direction of motor power cable:

- to side A
 - to side B
 - to the right
 - to the left
- } looking towards motor shaft

The output direction depicted is side A. The dimensions for other output directions can be obtained by turning the housing around the Z axis.

2 Custom diameter:

- $\varnothing 180j6$

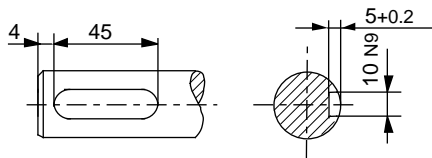
3 Holding brake:

- holding brake of 14 Nm
- holding brake of 40 Nm
- holding brake of 60 Nm

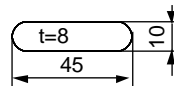
Table for 14Nm holding brake	Table for 40 and 60 Nm holding brake	Dim. A	Connector	
			INS 108	INS 172
does not affect outer dimensions	Size		S5	S5
	MDD 112 B	437	99	105.5
	MDD 112 C	512		
	MDD 112 D	587		

4 Output shaft:

- plain shaft (preferred type)
- with keyway per DIN 6885 sh. 1 (Note: balanced with entire key!)



matching key: DIN 6885-A 10x8x45



MBMDD112O

Figure 3.40: Options-dependent dimensions for MDD 112 (liquid-cooled)

3.3.5. MDD 112 - type codes

Type codes:	Example:	M	D	D	1	1	2	B	-	F	-	0	2	0	-	N	2	L	-	1	3	0	G	B	0	/	S	0	0	0
1. Designation Motor for digital drives	MDD																													
2. Motor size	112																													
3. Motor length	A, B, C, D																													
4. Housing: for liquid-cooling	F																													
5. Rated speed 1500 min ⁻¹ 2000 min ⁻¹ 3000 min ⁻¹ 4000 min ⁻¹	015 020 030 040																													
6. Balance class N per DIN ISO 2373 R per DIN ISO 2373	N R																													
7. Shaft end on side B standard (without second shaft end)	2																													
8. Motor feedback digital servo feedback digital servo feedback with integrated multiturn encoder	L M																													
9. Centering diameter ø130 mm ø180 mm	130 180																													
10. Output shaft plain shaft shaft with keyway per DIN 6885 Sh. 1	G P																													
11. Output direction of power connection To side A To side B To the right (looking towards shaft, housing on top) To the left (looking towards shaft, housing on top)	R L																													
12. Holding brake no holding brake with holding brake 14.0 Nm with holding brake 40.0 Nm with holding brake 60.0 Nm	0 1 2 ¹⁾ 3 ¹⁾																													
13. Custom version Determined and documented by Indramat with custom number. Field 13 does not apply to standard motors																														

¹⁾ Not with MDD 112A

Figure 3.41: Options for MDD 112 (liquid-cooled)

3.4. MDD 115 (liquid-cooled)

3.4.1. MDD 115 - motor data

Designation	Symbol	Unit			
			115A-F-015	115A-F-020	115A-F-030
Motor type MDD . . .					
Basic motor speed ¹⁾	n	min ⁻¹	1500	2000	3000
Continuous stall torque	M_{dN}	Nm	42.0	42.0	41.6
Continuous stall current	I_{dN}	A	39.6	52.9	80.6
Theor. maximum speed ²⁾	M_{max}	Nm	87.0	87.3	87.0
Peak current	I_{max}	A	93.9	125	191
Rotor inertia ³⁾	J_M	kgm ²	0.0123	0.0123	0.0123
Torque constant at 20 °C	K_m	Nm/A	1.34	1.01	0.66
Windings resistance at 20 °C	R_A	Ohm	0.54	0.30	0.13
Windings inductance	L_A	mH	11.8	6.7	3,0
Thermal time constant	T_{th}	min	45	45	45
Mass ³⁾	m_M	kg	33	33	33
Rated power loss	P_{vN}	W	840		
Ambient temperature ⁴⁾	ϑ_{amb}	°C	+5° to +45°		
Coolant entry temperature	ϑ_{ein}	°C	+10° to +40°		
Coolant temperature increase with P_{vN}	$\Delta\vartheta_N$	°C	10		
Minimum coolant flow through with $\Delta\vartheta_N$ ⁵⁾	Q_N	l/min	1.2		
Pressure drop with Q_N ^{5) 6)}	Δp_N	bar	0.6		
Maximum system pressure	p_{max}	bar	3		
Volume in coolant canal	V	l			
Storage and transportation temperature ⁷⁾	ϑ_L	°C	-20° to +80°		
Maximum installation altitude		m	1000 meters above sea level		
Protection category			IP 65		
Insulation classification			F		
Housing finish			prime coat black (RAL 9005)		
<u>options</u> <u>holding brake, electrical release</u>					
Holding torque	M_{H}	Nm	45		60
Rated voltage	U_N	V	24 ± 10%		24 ± 10%
Rated current	I_N	A	0.96		1.35
Inertia	J_B	kgm ²	9.5 x 10 ⁻⁴		32 x 10 ⁻⁴
Release delay	t_L	ms	55		150
Clamping delay	t_K	ms	18		30
Mass	m_B	kg	1.9		3.5
<p>1) Usable motor speed is determined by the torque requirements of the application. The usable speeds n_{max} found in the selection lists of the motor-drive combinations are binding for standard applications. The usable speeds for other applications can be found using the required torque in the torque-speed characteristics curves.</p> <p>2) The maximum achievable torque depends upon the drive used. Only those maximum torques M_{max} found in the selection list of the motor-drive combinations are binding.</p> <p>3) Without holding brake.</p> <p>4) Note the relationship between the actual ϑ_{amb} and the ϑ_{ein}: ϑ_{ein} may be no more than 5 °C below ϑ_{amb}!</p> <p>5) With coolant water.</p> <p>6) Note flow diagram for deviating flow values.</p> <p>7) Empty of all coolant prior to transportation or storage.</p>					

Figure 3.42: Technical data for MDD 115A (liquid-cooled)

3. Technical data

Designation	Symbol	Unit				
Motor type MDD . . .			115B-F-015	115B-F-020	115B-F-030	
Basic motor speed ¹⁾	n	min ⁻¹	1500	2000	3000	
Continuous stall torque	M_{dN}	Nm	72.2	72.2	47.3	
Continuous stall current	I_{dN}	A	51.5	80.4	102.9	
Theor. maximum speed ²⁾	M_{max}	Nm	118	118	117	
Peak current	I_{max}	A	122	191	368	
Rotor inertia ³⁾	J_M	kgm ²	0.0172	0.0172	0.0172	
Torque constant at 20 °C	K_m	Nm/A	1.40	0.90	0.46	
Windings resistance at 20 °C	R_A	Ohm	0.39	0.16	0.04	
Windings inductance	L_A	mH	9.2	4.1	2.0	
Thermal time constant	T_{th}	min	45	45	45	
Mass ³⁾	m_M	kg	41	41	41	
Rated power loss	P_{vN}	W	1040			
Ambient temperature ⁴⁾	ϑ_{amb}	°C	+5° to +45°			
Coolant entry temperature	ϑ_{ein}	°C	+10° to +40°			
Coolant temperature increase with P_{vN}	$\Delta\vartheta_N$	°C	10			
Minimum coolant flow through with $\Delta\vartheta_N$ ⁵⁾	Q_N	l/min	1.5			
Pressure drop with Q_N ^{5) 6)}	Δp_N	bar	0.8			
Maximum system pressure	p_{max}	bar	3			
Volume in coolant canal	V	l				
Storage and transportation temperature ⁷⁾	ϑ_L	°C	-20° to +80°			
Maximum installation altitude		m	1000 meters above sea level			
Protection category			IP 65			
Insulation classification			F			
Housing finish			prime coat black (RAL 9005)			
<u>options</u>						
<u>holding brake, electrical release</u>						
Holding torque	M_H	Nm	45		60	
Rated voltage	U_N	V	24 ± 10%		24 ± 10%	
Rated current	I_N	A	0.96		1.35	
Inertia	J_B	kgm ²	9.5 x 10 ⁻⁴		32 x 10 ⁻⁴	
Release delay	t_L	ms	55		150	
Clamping delay	t_K	ms	18		30	
Mass	m_B	kg	1.9		3.5	
<p>¹⁾ Usable motor speed is determined by the torque requirements of the application. The usable speeds n_{max} found in the selection lists of the motor-drive combinations are binding for standard applications. The usable speeds for other applications can be found using the required torque in the torque-speed characteristics curves.</p> <p>²⁾ The maximum achievable torque depends upon the drive used. Only those maximum torques M_{max} found in the selection list of the motor-drive combinations are binding.</p> <p>³⁾ Without holding brake.</p> <p>⁴⁾ Note the relationship between the actual ϑ_{amb} and the ϑ_{ein}: ϑ_{ein} may be no more than 5 °C below ϑ_{amb}!</p> <p>⁵⁾ With coolant water.</p> <p>⁶⁾ Note flow diagram for deviating flow values.</p> <p>⁷⁾ Empty of all coolant prior to transportation or storage.</p>						

Figure 3.43: Technical data for MDD 115B (liquid-cooled)

3. Technical data

Designation	Symbol	Unit			
Motor type MDD . . .			115C-F-015	115C-F-020	115C-F-030
Basic motor speed ¹⁾	n	min ⁻¹	1500	2000	3000
Continuous stall torque	M_{dN}	Nm	89.3	89.3	62.8
Continuous stall current	I_{dN}	A	76.3	97.9	102.9
Theor. maximum speed ²⁾	M_{max}	Nm	146	146	146
Peak current	I_{max}	A	181	232	346
Rotor inertia ³⁾	J_M	kgm ²	0.0222	0.0222	0.0222
Torque constant at 20 °C	K_m	Nm/A	1.17	0.91	0.61
Windings resistance at 20 °C	R_A	Ohm	0.21	0.12	0.05
Windings inductance	L_A	mH	5.2	3.5	1.3
Thermal time constant	T_{th}	min	45	45	45
Mass ³⁾	m_M	kg	52	52	52
Rated power loss	P_{vN}	W	1190		
Ambient temperature ⁴⁾	ϑ_{amb}	°C	+5° to +45°		
Coolant entry temperature	ϑ_{ein}	°C	+10° to +40°		
Coolant temperature increase with P_{vN}	$\Delta\vartheta_N$	°C	10		
Minimum coolant flow through with $\Delta\vartheta_N$ ⁵⁾	Q_N	l/min	1.7		
Pressure drop with Q_N ^{5) 6)}	Δp_N	bar	0.9		
Maximum system pressure	p_{max}	bar	3		
Volume in coolant canal	V	l			
Storage and transportation temperature ⁷⁾	ϑ_L	°C	-20° to +80°		
Maximum installation altitude		m	1000 meters above sea level		
Protection category			IP 65		
Insulation classification			F		
Housing finish			prime coat black (RAL 9005)		
<u>options</u> <u>holding brake, electrical release</u>					
Holding torque	M_H	Nm	45		60
Rated voltage	U_N	V	24 ± 10%		24 ± 10%
Rated current	I_N	A	0.96		1.35
Inertia	J_B	kgm ²	9.5 x 10 ⁻⁴		32 x 10 ⁻⁴
Release delay	t_L	ms	55		150
Clamping delay	t_K	ms	18		30
Mass	m_B	kg	1.9		3.5
<p>1) Usable motor speed is determined by the torque requirements of the application. The usable speeds n_{max} found in the selection lists of the motor-drive combinations are binding for standard applications. The usable speeds for other applications can be found using the required torque in the torque-speed characteristics curves.</p> <p>2) The maximum achievable torque depends upon the drive used. Only those maximum torques M_{max} found in the selection list of the motor-drive combinations are binding.</p> <p>3) Without holding brake.</p> <p>4) Note the relationship between the actual ϑ_{amb} and the ϑ_{ein}: ϑ_{ein} may be no more than 5 °C below ϑ_{amb}!</p> <p>5) With coolant water.</p> <p>6) Note flow diagram for deviating flow values.</p> <p>7) Empty of all coolant prior to transportation or storage.</p>					

Figure 3.44: Technical data for MDD 115C (liquid-cooled)

3. Technical data

Designation	Symbol	Unit			
			115D-F-015	115D-F-020	
Motor type MDD . . .					
Basic motor speed ¹⁾	n	min ⁻¹	1500	2000	
Continuous stall torque	M_{dN}	Nm	108	76.1	
Continuous stall current	I_{dN}	A	73.2	102.9	
Theor. maximum speed ²⁾	M_{max}	Nm	177	177	
Peak current	I_{max}	A	173	347	
Rotor inertia ³⁾	J_M	kgm ²	0.0271	0.0271	
Torque constant at 20 °C	K_m	Nm/A	1.48	0.74	
Windings resistance at 20 °C	R_A	Ohm	0.25	0.06	
Windings inductance	L_A	mH	6.4	1.7	
Thermal time constant	T_{th}	min	90	90	
Mass ³⁾	m_M	kg	60	60	
Rated power loss	P_{vN}	W	1240		
Ambient temperature ⁴⁾	ϑ_{amb}	°C	+5° to +45°		
Coolant entry temperature	ϑ_{ein}	°C	+10° to +40°		
Coolant temperature increase with P_{vN}	$\Delta\vartheta_N$	°C	10		
Minimum coolant flow through with $\Delta\vartheta_N$ ⁵⁾	Q_N	l/min	1.8		
Pressure drop with Q_N ^{5) 6)}	Δp_N	bar	1.0		
Maximum system pressure	p_{max}	bar	3		
Volume in coolant canal	V	l			
Storage and transportation temperature ⁷⁾	ϑ_L	°C	-20° to +80°		
Maximum installation altitude		m	1000 meters above sea level		
Protection category			IP 65		
Insulation classification			F		
Housing finish			prime coat black (RAL 9005)		
<u>options</u>					
<u>holding brake, electrical release</u>					
Holding torque	M_H	Nm	45		60
Rated voltage	U_N	V	24 ± 10%		24 ± 10%
Rated current	I_N	A	0.96		1.35
Inertia	J_B	kgm ²	9.5 x 10 ⁻⁴		32 x 10 ⁻⁴
Release delay	t_L	ms	55		150
Clamping delay	t_K	ms	18		30
Mass	m_B	kg	1.9		3.5
<p>¹⁾ Usable motor speed is determined by the torque requirements of the application. The usable speeds n_{max} found in the selection lists of the motor-drive combinations are binding for standard applications. The usable speeds for other applications can be found using the required torque in the torque-speed characteristics curves.</p> <p>²⁾ The maximum achievable torque depends upon the drive used. Only those maximum torques M_{max} found in the selection list of the motor-drive combinations are binding.</p> <p>³⁾ Without holding brake.</p> <p>⁴⁾ Note the relationship between the actual ϑ_{amb} and the ϑ_{ein}: ϑ_{ein} may be no more than 5 °C below ϑ_{amb}!</p> <p>⁵⁾ With coolant water.</p> <p>⁶⁾ Note flow diagram for deviating flow values.</p> <p>⁷⁾ Empty of all coolant prior to transportation or storage.</p>					

Figure 3.45: Technical data for MDD 115D (liquid-cooled)

3.4.2. Torque-speed characteristics curves for MDD 115

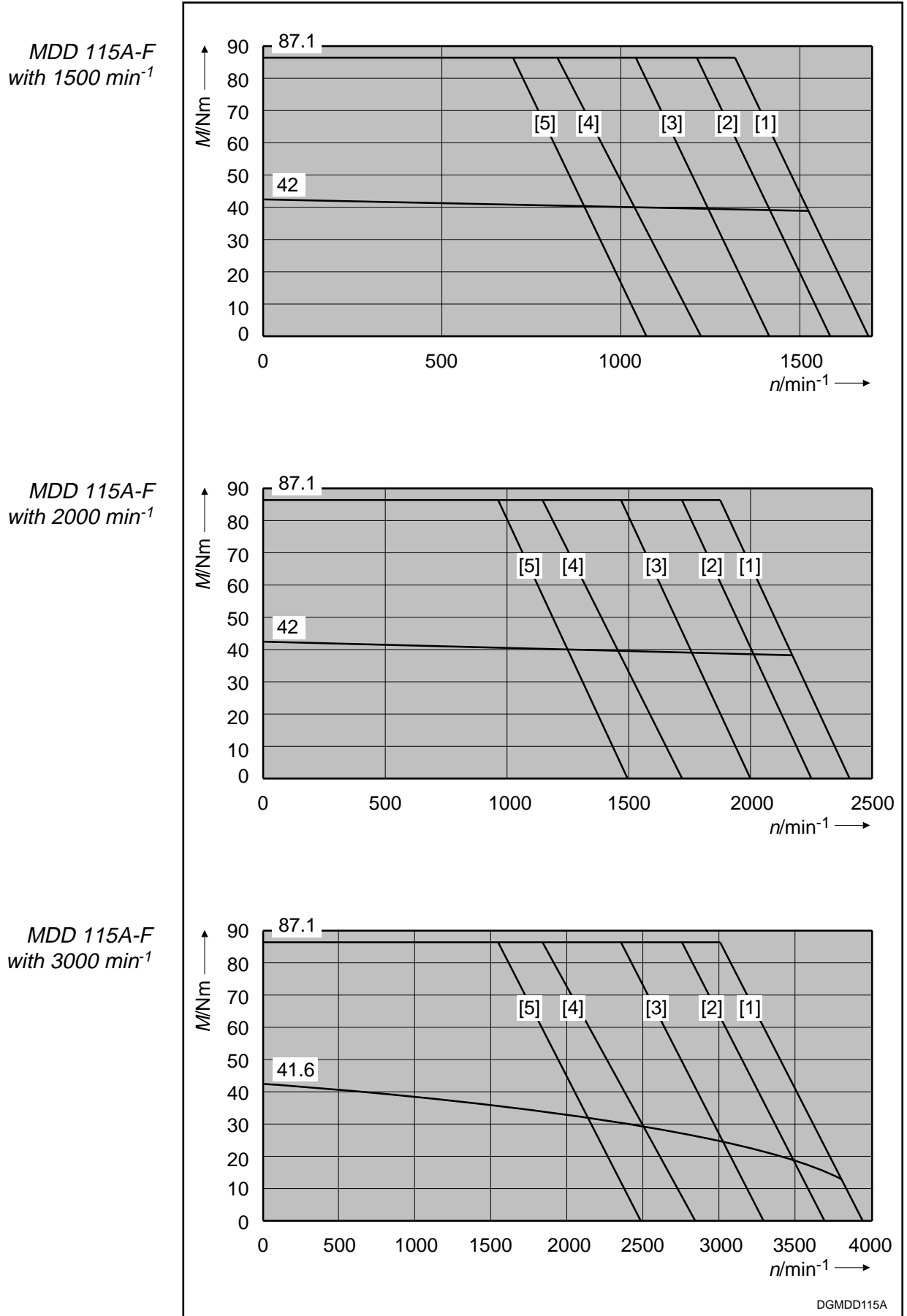
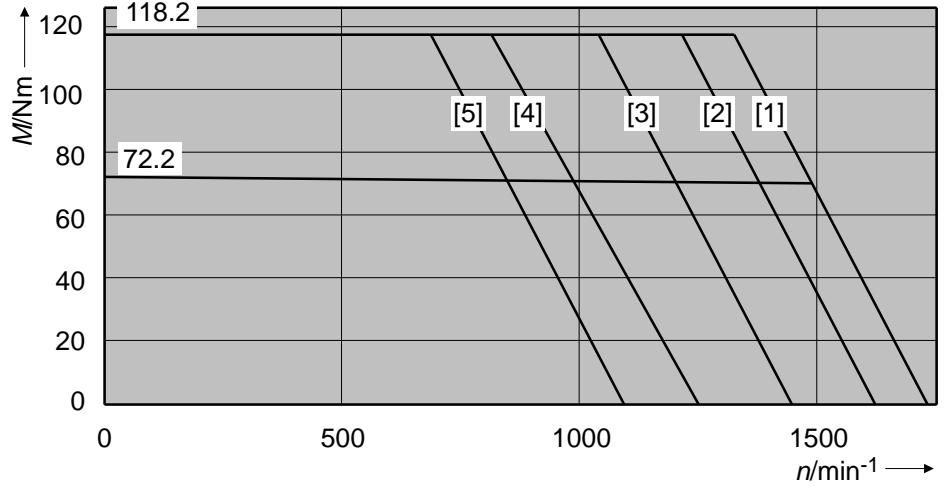
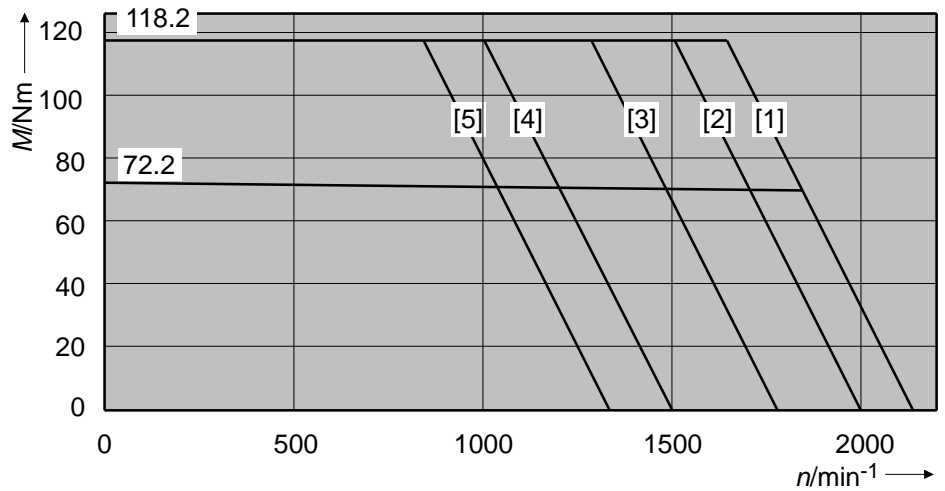


Figure 3.46: Torque-speed characteristics curves for MDD 115A

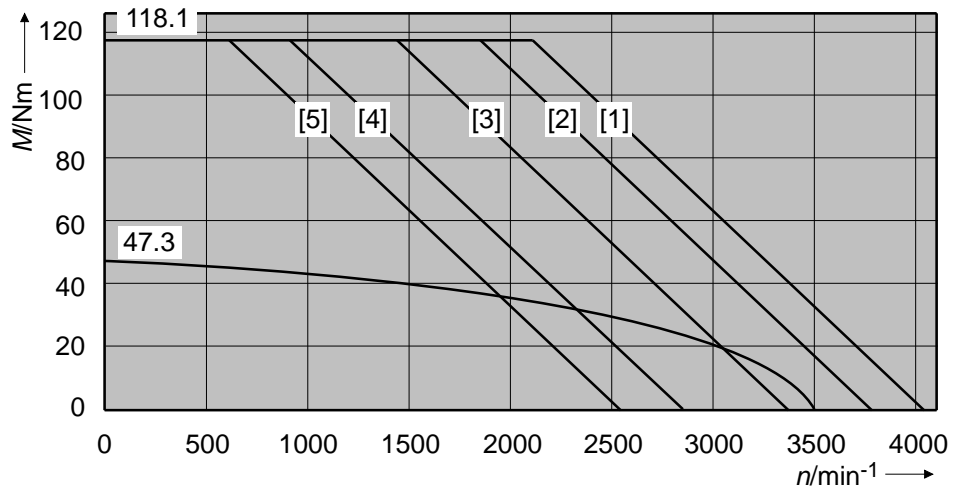
*MDD 115B-F
with 1500 min⁻¹*



*MDD 115B-F
with 2000 min⁻¹*



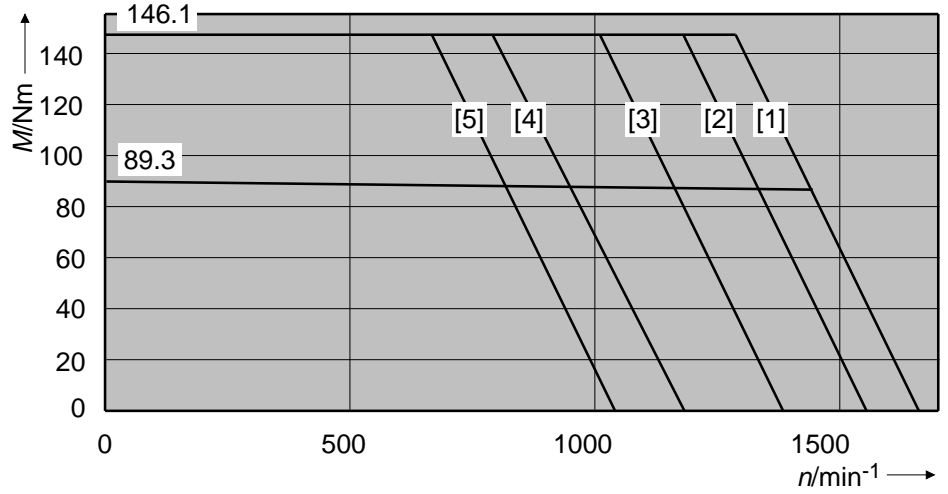
*MDD 115B-F
with 3000 min⁻¹*



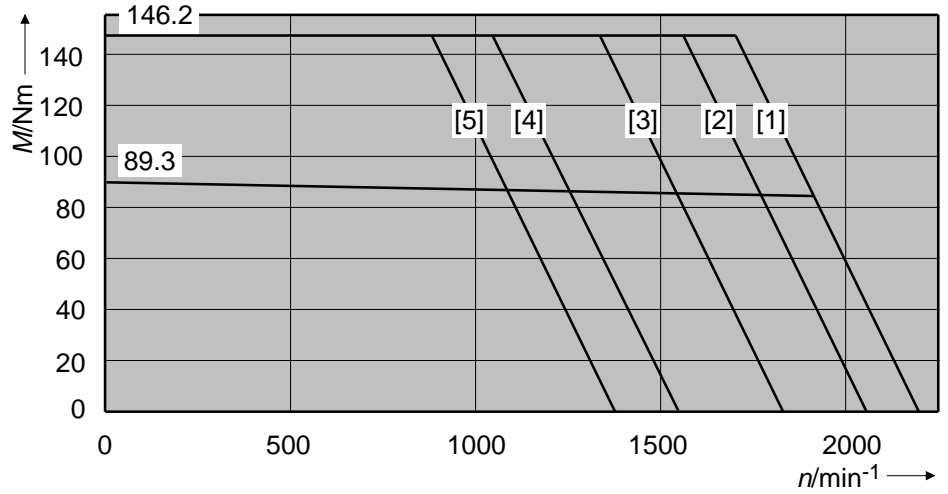
DGMDD115B

Figure 3.47: Torque-speed characteristics curves for MDD 115B

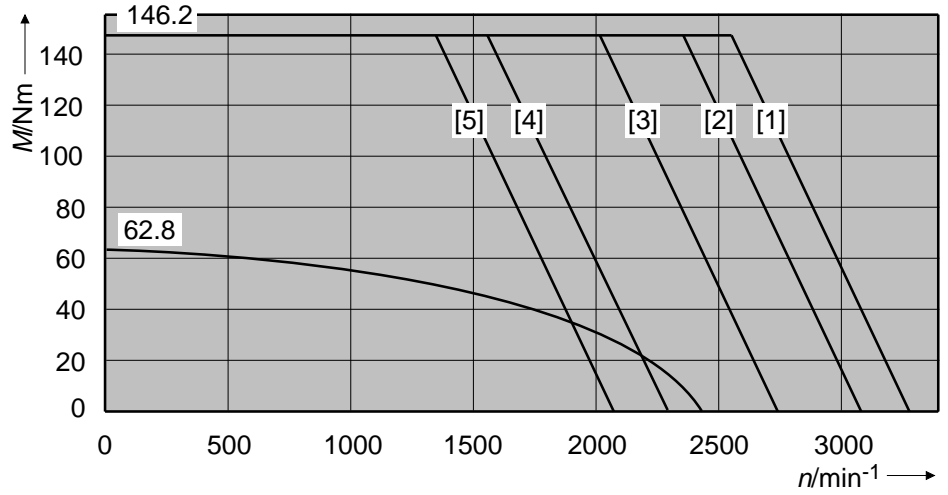
*MDD 115C-F
with 1500 min⁻¹*



*MDD 115C-F
with 2000 min⁻¹*



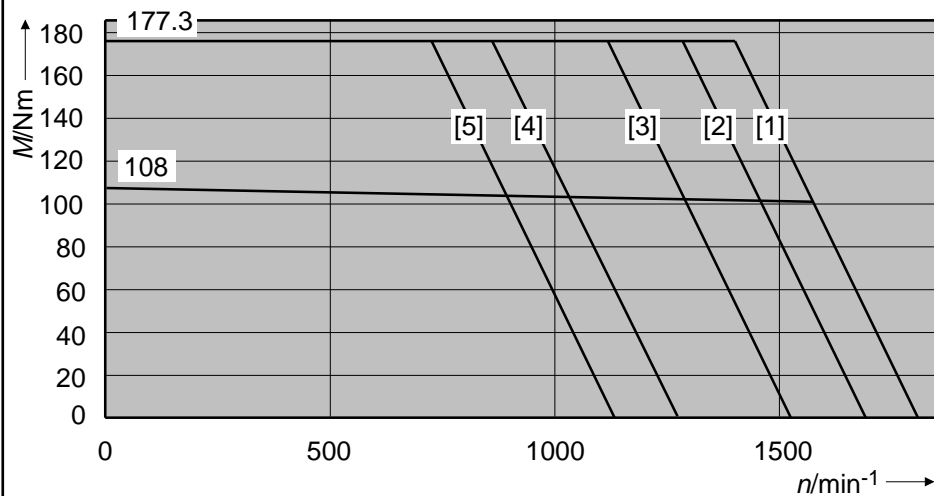
*MDD 115C-F
with 3000 min⁻¹*



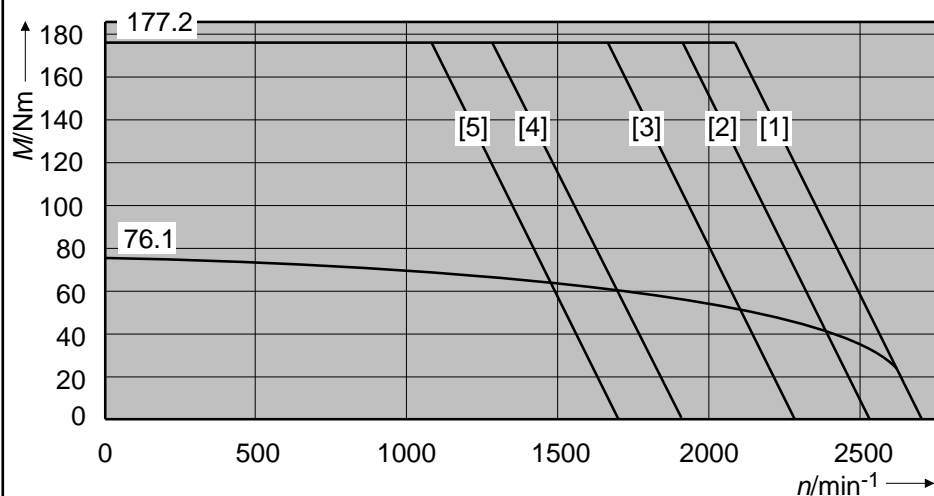
DGMDD115C

Figure 3.48: Torque-speed characteristics curves for MDD 115C

*MDD 115D-F
with 1500 min⁻¹*



*MDD 115D-F
with 2000 min⁻¹*



DGMDD115D

Figure 3.49: Torque-speed characteristics curves for MDD 115D

3.4.3. MDD 115 - shaft load

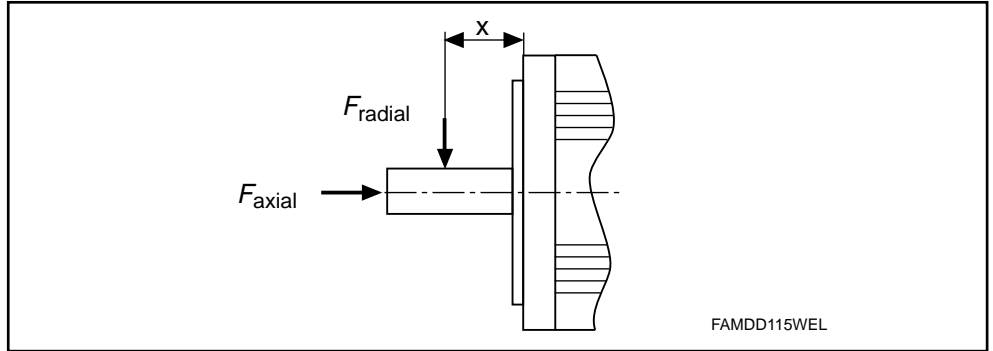


Figure 3.50: Shaft load

Radial force F_{radial}

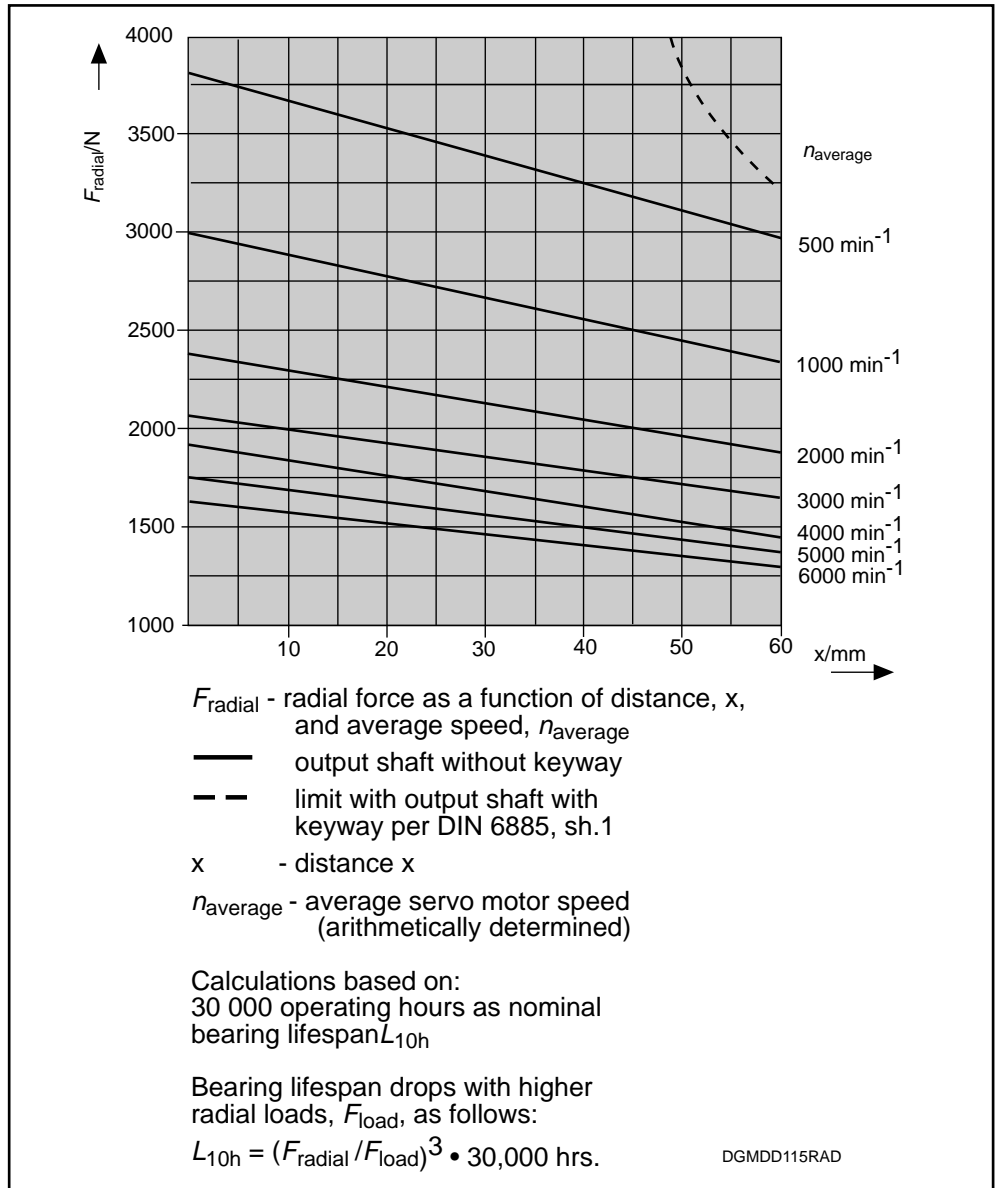


Figure 3.51: Radial force

Axial force F_{axial}

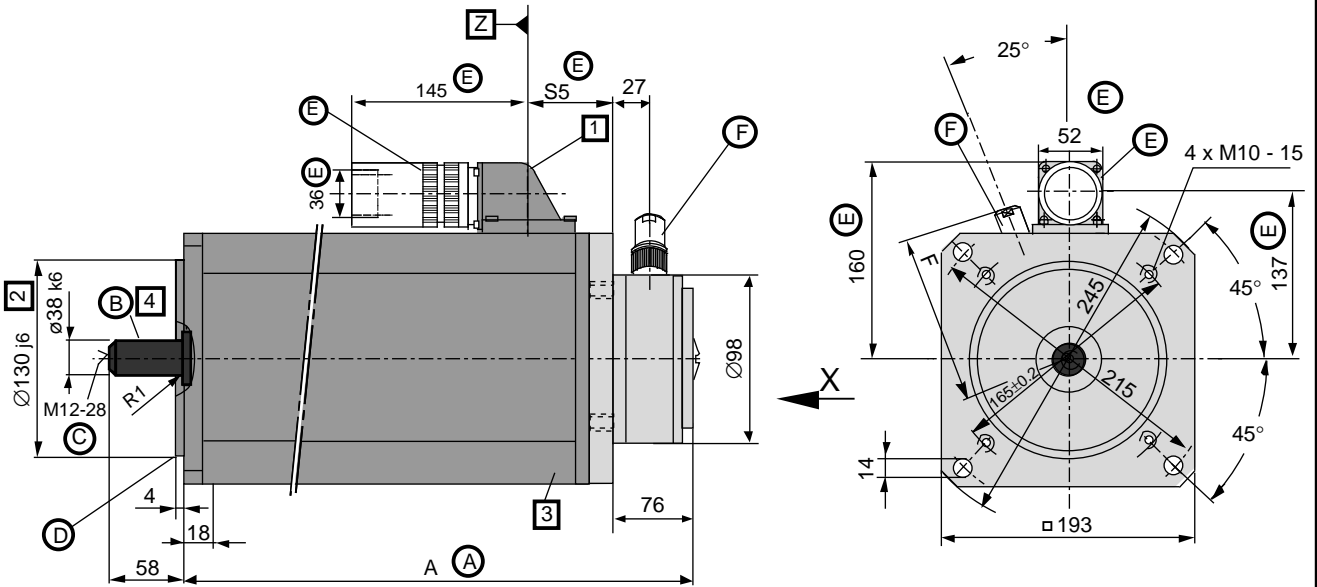
$$F_{axial} = 0.35 \cdot F_{radial}$$

F_{axial} - permissible axial force

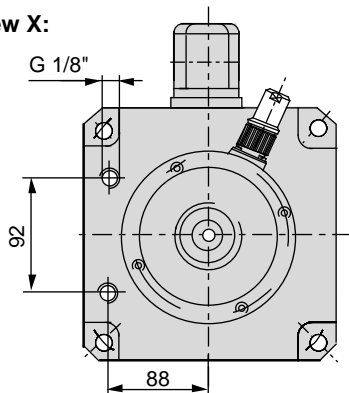
F_{radial} - permissible radial force

3.4.4. Maßangaben MDD 115

General dimensions:



View X:



- Ⓓ Flange determines mounting mode
 - per design B5 (drill hole in flange)
 - per design B14 (windings in flange)

- Ⓔ Motor power connector:
Not supplied with motor.

Table:

Dim. Type	S5
INS 172	62.5

Ⓐ Table:

Size	Dim.A 1)
MDD 115 A	359
MDD 115 B	409
MDD 115 C	459
MDD 115 D	509

1) Larger with some options.
The applicable dimension is given with the option.

- Ⓑ position accuracy per tolerance R DIN 42 955
- Ⓒ center drill hole DS M12 per DIN 332, sh. 2

- Ⓕ Feedback connector:
Not supplied with motor.

Table:

Name	Connector	Dim. F
straight	INS 513	110
	INS 512	112
elbow	INS 511 INS 510	108

MBMDD115A

Figure 3.52: General data on MDD 115 (liquid-cooled)

Option-dependent dimensions:

1 Mounting direction of the power connection:

- to side A
 - to side B
 - to the right
 - to the left
- } looking towards motor shaft

The output direction depicted is side A. The dimensions for other output directions are obtained by turning the housing around the Z axis.

2 Custom diameter:

- $\varnothing 180j6$

3 Holding brake:

- holding brake of 45 Nm
- holding brake of 60 Nm

Table for 45Nm holding torque	Table for 60Nm holding torque		
	Size	Dim. A	Dim. S5
does not affect outer dimensions	MDD 115 A	419	105.5
	MDD 115 B	469	
	MDD 115 C	519	
	MDD 115 D	569	

4 Output shaft:

- plain shaft (preferred type)
- with key per DIN 6885, sh. 1 (Note: balanced with entire key!)



MBMDD115O

Figure 3.53: Options-dependent dimensions for MDD 115 (liquid-cooled)

3.4.5. MDD 115 - type codes

Type codes:	Example:	MDD115B-F-020-N2L-130GB0/S000
1. Designation Motor for digital drives	MDD	MDD
2. Motor size	115	115
3. Motor length	A, B, C, D	B
4. Housing: for liquid-cooling	F	F
5. Rated speed 1500 min ⁻¹ 2000 min ⁻¹ 3000 min ⁻¹	015 020 030 ¹⁾	020
6. Balance class N per DIN ISO 2373 R per DIN ISO 2373	N R	N
7. Shaft end on side B standard (without second shaft end)	2	2
8. Motor feedback digital servo feedback digital servo feedback with integrated multiturn encoder	L M	L
9. Centering diameter ø130 mm ø180 mm	130 180	130
10. Output shaft plain shaft shaft with keyway per DIN 6885 Sh. 1	G P	G
11. Output direction of power connection To side A To side B To the right (looking towards shaft, housing on top) To the left (looking towards shaft, housing on top)	R L	R
12. Holding brake no holding brake with holding brake of 45.0 Nm with holding brake of 60.0 Nm	0 1 2	0
13. Custom version Determined and documented by INDRAMAT with custom number Field 13 does not apply to standard motors		000

¹⁾ Not with motor length „D“

Figure 3.54: Options for MDD 115 (liquid-cooled)

4. Electrical power connections

4.1. Terminal diagram

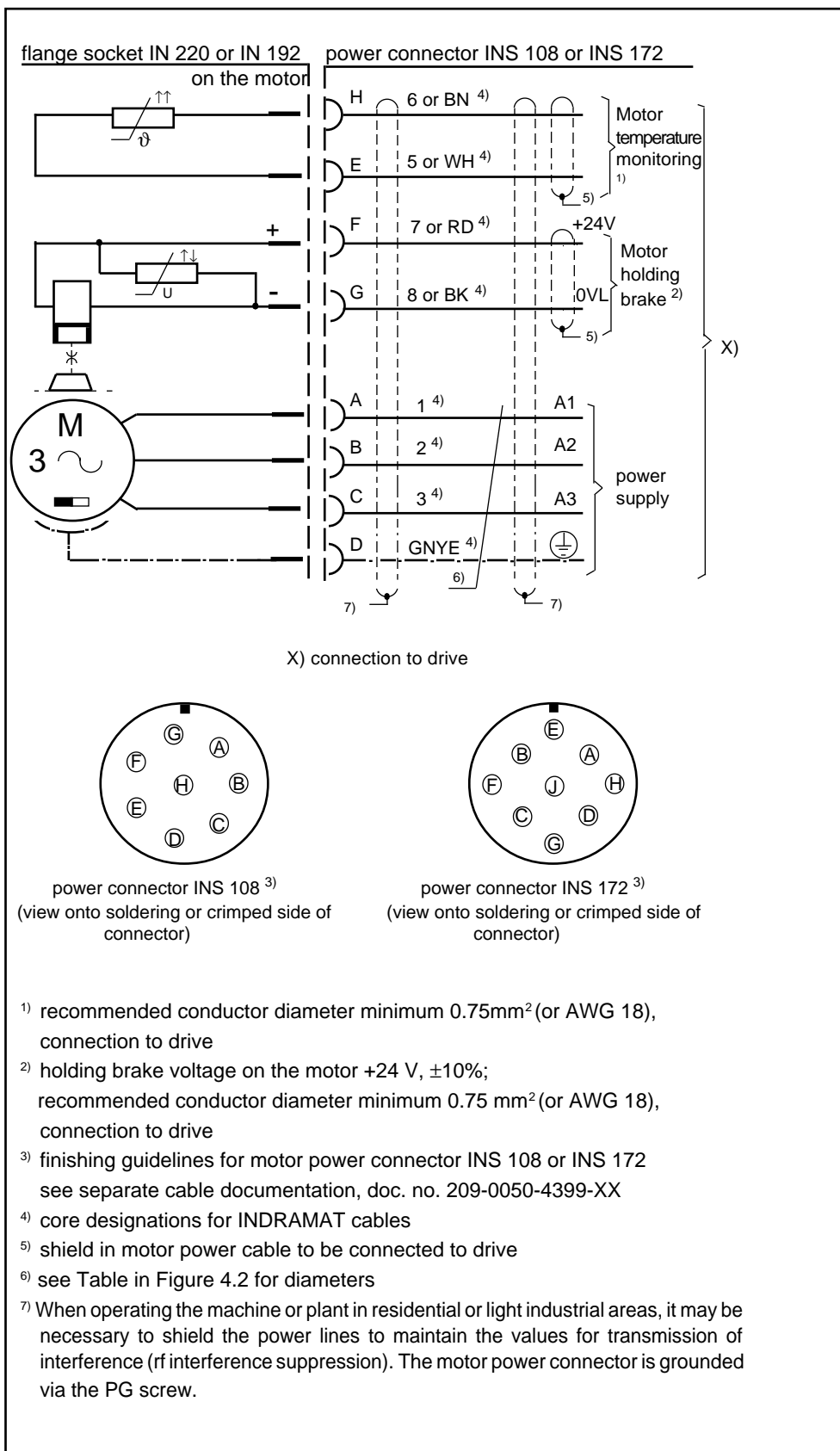


Figure 4.1: Power connections

4.2. Connector to cable allocation

Servo motor MDD ...	Motor phase current* (A)	Minimum diameter power connection* (mm ²) (AWG) 1)		Motor power connector		INDRAMAT motor power cable			
				crimping type 2)	soldering type 2)	no shield		with shield type	dia- meter (mm ²)
						standard type	flexible type		
090 A-F-020	6.1	0.75	18	---	INS 108/06	INK 253	---	INK 653	0.75
090 A-F-030	9.5	1.0	18	---	INS 108/06	INK 250	---	INK 650	1.5
090 A-F-040	14.4	1.5	16	INS 108/02	INS 108/06	INK 250	---	INK 650	1.5
090 B-F-020	12.8	1.5	16	INS 108/02	INS 108/06	INK 250	---	INK 650	1.5
090 B-F-030	19.3	2.5	14	INS 108/03	INS 108/06	INK 202	INK 402 ³⁾	INK 602	2.5
090 B-F-040	25.6	4.0	12	INS 108/04	INS 108/06	INK 203	INK 403 ⁴⁾	INK 603	4.0
090 C-F-020	18.5	2.5	12	INS 108/03	INS 108/06	INK 202	INK 402 ³⁾	INK 602	2.5
090 C-F-030	30.0	6.0	10	INS 172/06	INS 172/25	INK 204	INK 404 ⁴⁾	INK 604	6.0
090 C-F-040	37.0	10.0	10	INS 172/10	INS 172/25	INK 205	INK 405	INK 605	10.0
093 A-F-020	15.8	2.5	14	INS 108/03	INS 108/06	INK 202	INK 402 ³⁾	INK 602	2.5
093 A-F-030	27.7	4.0	12	INS 108/04	INS 108/06	INK 203	INK 403 ⁴⁾	INK 603	4.0
093 A-F-040	36.1	6.0	10	INS 172/06	INS 172/25	INK 204	INK 404	INK 604	6.0
093 A-F-060	57.2	16.0	8	INS 172/16	INS 172/25	INK 206	INK 406	INK 606	16.0
093 B-F-020	26.2	4.0	10	INS 108/04	INS 108/06	INK 203	INK 403 ⁴⁾	INK 603	4.0
093 B-F-030	37.3	10.0	10	INS 172/10	INS 172/25	INK 205	INK 405	INK 605	10.0
093 B-F-040	56.8	16.0	6	INS 172/16	INS 172/25	INK 206	INK 406	INK 606	16.0
093 B-F-060	72.5	25.0	4	---	INS 172/25	INK 207	INK 407	INK 607	25.0
093 C-F-020	33.3	6.0	10	INS 172/06	INS 172/25	INK 204	INK 404	INK 604	6.0
093 C-F-030	50.0	10.0	8	INS 172/10	INS 172/25	INK 205	INK 405	INK 605	10.0
093 C-F-040	70.3	25.0	6	---	INS 172/25	INK 207	INK 407	INK 607	25.0
093 C-F-060	86.0	25.0	3	---	INS 172/25	INK 207	INK 407	INK 607	25.0
093 D-F-015	40.0	10.0	8	INS 172/10	INS 172/25	INK 205	INK 405	INK 605	10.0
093 D-F-020	51.0	16.0	6	INS 172/16	INS 172/25	INK 206	INK 406	INK 606	16.0
093 D-F-030	68.0	25.0	4	---	INS 172/25	INK 207	INK 407	INK 607	25.0
093 D-F-040	84.0	25.0	3	---	INS 172/25	INK 207	INK 407	INK 607	25.0
112 A-F-015	12.7	1.5	16	INS 108/02	INS 108/06	INK 250	---	INK 650	1.5
112 A-F-020	18.0	2.5	14	INS 108/03	INS 108/06	INK 202	INK 402 ³⁾	INK 602	2.5
112 A-F-030	26.2	4.0	12	INS 108/04	INS 108/06	INK 203	INK 403 ⁴⁾	INK 603	4.0
112 A-F-040	34.8	6.0	10	INS 172/06	INS 172/25	INK 204	INK 404	INK 604	6.0
112 B-F-015	22.6	4.0	10	INS 108/04	INS 108/06	INK 203	INK 403 ⁴⁾	INK 603	4.0
112 B-F-020	31.8	6.0	10	INS 172/06	INS 172/25	INK 204	INK 404	INK 604	6.0
112 B-F-030	43.1	10.0	8	INS 172/10	INS 172/25	INK 205	INK 405	INK 605	10.0
112 B-F-040	63.6	16.0	4	INS 172/16	INS 172/25	INK 207	INK 407	INK 607	25.0
112 C-F-015	33.9	6.0	10	INS 172/06	INS 172/25	INK 204	INK 404	INK 604	6.0
112 C-F-020	45.4	10.0	8	INS 172/10	INS 172/25	INK 205	INK 405	INK 605	10.0
112 C-F-030	65.7	16.0	6	INS 172/16	INS 172/25	INK 206	INK 406	INK 606	16.0
112 C-F-040	84.0	25.0	3	---	INS 172/25	INK 207	INK 407	INK 607	25.0
112 D-F-015	45.3	10.0	8	INS 172/10	INS 172/25	INK 205	INK 405	INK 605	10.0
112 D-F-020	66.6	16.0	6	INS 172/16	INS 172/25	INK 206	INK 406	INK 606	16.0
112 D-F-030	84.0	25.0	3	---	INS 172/25	INK 207	INK 407	INK 607	25.0
112 D-F-040	84.0	25.0	3	---	INS 172/25	INK 207	INK 407	INK 607	25.0

* Motor phase currents and power connections apply to S1 continuous operation

- 1) Minimum diameter of power connection per EN 60 204, section 1, table 5, column C or E, or UL 508 table 50.2. but at least 0.75 mm² (or AWG 18); cable per UL 508 can only be soldered to the motor power connector, not crimped.
- 2) Data following the slash define the type of bushing of the motor power connector for either crimping or soldering.
- 3) Use INS 108/04 crimped, for motor power connector.
- 4) Only soldered motor power connector.

Figure 4.2: Allocation of connector to cables for the power connections

4. Electrical power connections

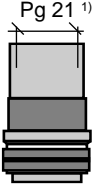
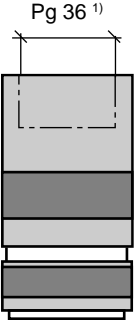
Servo motor MDD ...	Motor phase current * (A)	Minimum diameter power connection * (mm ²) (AWG) 1)		Motor power connector		INDRAMAT motor power cable			
				crimping type 2)	soldering type 2)	without shield		with shield type	dia- meter (mm ²)
						standard type	flexible type		
115 A-F-015	32.4	6.0	10	INS 172/06	INS 172/25	INK 204	INK 404	INK 604	6.0
115 A-F-020	43.2	10.0	8	INS 172/10	INS 172/25	INK 205	INK 405	INK 605	10.0
115 A-F-030	65.8	16.0	6	INS 172/16	INS 172/25	INK 206	INK 406	INK 606	16.0
115 B-F-015	42.0	10.0	8	INS 172/10	INS 172/25	INK 205	INK 405	INK 605	10.0
115 B-F-020	65.7	16.0	6	INS 172/16	INS 172/25	INK 206	INK 406	INK 606	16.0
115 B-F-030	84.0	25.0	3	---	INS 172/25	INK 207	INK 407	INK 607	25.0
115 C-F-015	62.3	16.0	6	INS 172/16	INS 172/25	INK 206	INK 406	INK 606	16.0
115 C-F-020	80.0	25.0	4	---	INS 172/25	INK 207	INK 407	INK 607	25.0
115 C-F-030	84.0	25.0	3	---	INS 172/25	INK 207	INK 407	INK 607	25.0
115 D-F-015	59.8	16.0	6	INS 172/16	INS 172/25	INK 206	INK 406	INK 606	16.0
115 D-F-020	84.0	25.0	3	---	INS 172/25	INK 207	INK 407	INK 607	25.0

* Motor phase current and connection diameters apply to S1 continuous operation

- 1) Minimum diameter of power connection per EN 60 204, section 1, table 5, column C or E or UL 508 table 50.2. but at least 0.75 mm² (or AWG 18); cable per UL 508 can only be soldered to the motor power connector, not crimped.
- 2) Data following the slash define the type of bushing of the motor power connector for either crimping or soldering.

Figure 4.3: Allocation of connector to cables for the power connections

4.3. Motor power connectors

	Crimping					Soldering				
	Connector	maximum connection diameter		strain relief ¹⁾		Connector	maximum connection diameter		strain relief ¹⁾	
		power core (mm ²)	control core ²⁾ (mm ²)	cable INK	part number		power core	control core ²⁾ maximum	cable INK	part number
INS 108 	INS 108/02	1.5	1.5	250 650	225 404 257 121 ⁴⁾	INS 108/06	0.75 - 6.0 mm ²	1.5 mm ²	253 250 202 203 204	225 404 225 404 219 857 218 767 218 767
	INS 108/03	2.5	1.5	202 602	219 857 254 917				402 403 404	227 526 219 857 218 767
	INS 108/04	4.0	1.5	203 402 603	218 767 227 526 253 053		AWG 18 - 10	AWG 16	653 650 602 603 604	252 651 ⁴⁾ 257 121 ³⁾ 254 917 253 053 253 053
INS 172 	INS 172/06	6.0	1.5	204 404 604	220874 ³⁾ 228864 ³⁾ 253053 ³⁾	INS 172/25	4.0 - 25.0 mm ²	1.5 mm ²	203 204 205 206 207	220874 ³⁾ 220874 ³⁾ 220472 ³⁾ 220472 ³⁾ 220473
	INS 172/10	10.0	1.5	205 405 605	220472 ³⁾ 221554 ³⁾ 257120 ³⁾				403 404	228864 ³⁾ 220874 ³⁾
	INS 172/16	16.0	1.5	206 406 606	220472 ³⁾ 221554 ³⁾ 252653 ³⁾		AWG 10 - 3	AWG 16	405 406 407 603 604 605 606 607	221554 ³⁾ 220472 ³⁾ 220472 ³⁾ 253053 ⁶⁾ 253053 ⁶⁾ 257120 ⁶⁾ 252653 252653

¹⁾ Threaded PG joints should be mounted into the motor power connector to ensure trouble-free operation. They are not delivered with the motor power connector. INDRAMAT makes these parts available. They can be ordered to match the cable types by using the above listed parts number.
²⁾ For monitoring of motor holding brake and temperature.
³⁾ Further reduction requires part number 220 474
⁴⁾ Further reduction requires part number 252 652
⁵⁾ Further reduction requires part number 252 652
⁶⁾ Further reduction requires parts 220 474 and 221 024

Figure 4.4: Motor power connectors

4.4. Motor power cables - technical data

type	power core diameter (mm ²)	control core ¹⁾ diameter (mm ²)	total shield	power cable diameter (mm)	minimum bending radius		specific weight kg/m
					fixed routing (mm)	flexible routing ²⁾ (mm)	
INK 253	0.75	0.34	–	10 ± 1	50	90	0.11
INK 250	1.5	0.75	–	11 ± 1	70	110	0.19
INK 202	2.5	1.5	–	17.3 ± 0.5	120	200	0.47
INK 203	4.0	1.5	–	18.6 ± 0.5	120	270	0.57
INK 204	6.0	1.5	–	20 ± 0.6	120	300	0.67
INK 205	10.0	1.5	–	26 ± 0.7	200	380	1.10
INK 206	16.0	1.5	–	27 ± 0.7	220	390	1.33
INK 207	25.0	1.5	–	30.5 ± 0.8	240	430	1.70
INK 402	2.5	0.75	–	13.5 ± 1	85	140	0.27
INK 403	4.0	0.75 or 1.0	–	15.5 ± 1	95	160	0.37
INK 404	6.0	0.75 or 1.0	–	18 ± 1	105	175	0.50
INK 405	10.0	0.75 or 1.0	–	21.5 ± 1	130	220	0.74
INK 406	16.0	1.0	–	25.0 ± 1	150	250	1.10
INK 407	25.0	1.5	–	26.0 ± 1	180	270	1.52
INK 653	0.75	0.34	+	9.6 ± 0.3	70	100	0.25
INK 650	1.5	0.75	+	12.2 ± 0.4	80	120	0.39
INK 602	2.5	0.75	+	14.8 ± 0.5	85	140	0.59
INK 603	4.0	0.75 or 1.0	+	16.9 ± 0.5	110	180	0.60
INK 604	6.0	0.75 or 1.0	+	18.8 ± 0.6	120	195	0.81
INK 605	10.0	0.75 or 1.0	+	23.8 ± 0.5	150	240	1.10
INK 606	16.0	1.0	+	28.2 ± 0.6	160	280	1.40
INK 607	25.0	1.5	+	27.6 ± 0.5	190	270	1.73

¹⁾ For monitoring of holding brake and temperature
²⁾ Working life equals more than 500,000 bending loads

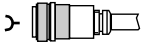
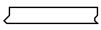
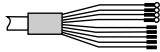
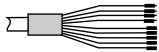
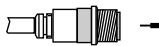
Figure 4.5: Type-dependent data of the motor power connection

General information

Protection category	cable to connector transition IP 65
chemical characteristics	absolute resistance to mineral oils and greases, hydrolysis resistance, silicone and halogen free
permissible ambient temperature for operation and storages	from -30 °C to +80 °C
cable surface	does not adhere, prevents sticking in drag chains
cable length	maximum 75 meters

Figure 4.6: General data on the motor power cables

4.5. Ready-made motor power cables

Motor type MDD...	Motor power connector 	Motor power cable power core diameter mm ² 	Cable ends for		
			connected to drive with bolts (e.g., DDS 2) 	intermediate clamp to clamping strip or connected to drive with clamps (e.g., DKS, DDS 3, DKC) 	plug adapter with coupler unit 1) 
090A-F-020	INS 108/06	0.75	IK• 011	IK• 012	IK• 003
090A-F-030	INS 108/06	1.5	IK• 021	IK• 022	IK• 023
090A-F-040	INS 108/02	1.5	IK• 021	IK• 022	IK• 023
090B-F-020	INS 108/02	1.5	IK• 021	IK• 022	IK• 023
090B-F-030	INS 108/03	2.5	IK• 041	IK• 042	IK• 043
090B-F-040	INS 108/04	4.0	IK• 061	IK• 062	IK• 063
090C-F-020	INS 108/03	2.5	IK• 041	IK• 042	IK• 043
090C-F-030	INS 172/06	6.0	IK• 101	IK• 102	IK• 108
090C-F-040	INS 172/10	10.0	IK• 121	IK• 122	IK• 128
093A-F-020	INS 108/03	2.5	IK• 041	IK• 042	IK• 043
093A-F-030	INS 108/04	4.0	IK• 061	IK• 062	IK• 063
093A-F-040	INS 172/06	6.0	IK• 101	IK• 102	IK• 108
093A-F-060	INS 172/16	16.0	IK• 141	IK• 142	IK• 148
093B-F-020	INS 108/04	4.0	IK• 061	IK• 062	IK• 063
093B-F-030	INS 172/10	10.0	IK• 121	IK• 122	IK• 128
093B-F-040	INS 172/16	16.0	IK• 141	IK• 142	IK• 148
093B-F-060	INS 172/25	25.0	IK• 161	IK• 162	IK• 168
093C-F-020	INS 172/06	6.0	IK• 101	IK• 102	IK• 108
093C-F-030	INS 172/10	10.0	IK• 121	IK• 122	IK• 128
093C-F-040	INS 172/25	25.0	IK• 161	IK• 162	IK• 168
093C-F-060	INS 172/25	25.0	IK• 161	IK• 162	IK• 168
093D-F-015	INS 172/10	10.0	IK• 121	IK• 122	IK• 128
093D-F-020	INS 172/16	16.0	IK• 141	IK• 142	IK• 148
093D-F-030	INS 172/25	25.0	IK• 161	IK• 162	IK• 168
093D-F-040	INS 172/25	25.0	IK• 161	IK• 162	IK• 168
112A-F-015	INS 108/02	1.5	IK• 021	IK• 022	IK• 023
112A-F-020	INS 108/03	2.5	IK• 041	IK• 042	IK• 043
112A-F-030	INS 108/04	4.0	IK• 061	IK• 062	IK• 063
112A-F-040	INS 172/06	6.0	IK• 101	IK• 102	IK• 108
112B-F-015	INS 108/04	4.0	IK• 061	IK• 062	IK• 063
112B-F-020	INS 172/06	6.0	IK• 101	IK• 102	IK• 108
112B-F-030	INS 172/10	10.0	IK• 121	IK• 122	IK• 128
112B-F-040	INS 172/16	25.0	IK• 161	IK• 162	IK• 168
112C-F-015	INS 172/06	6.0	IK• 101	IK• 102	IK• 108
112C-F-020	INS 172/10	10.0	IK• 121	IK• 122	IK• 128
112C-F-030	INS 172/16	16.0	IK• 141	IK• 142	IK• 148
112C-F-040	INS 172/25	25.0	IK• 161	IK• 162	IK• 168
112D-F-015	INS 172/10	10.0	IK• 121	IK• 122	IK• 128
112D-F-020	INS 172/16	16.0	IK• 141	IK• 142	IK• 148
112D-F-030	INS 172/25	25.0	IK• 161	IK• 162	IK• 168
112D-F-040	INS 172/25	25.0	IK• 161	IK• 162	IK• 168
115A-F-015	INS 172/06	6.0	IK• 101	IK• 102	IK• 108
115A-F-020	INS 172/10	10.0	IK• 121	IK• 122	IK• 128
115A-F-030	INS 172/16	16.0	IK• 141	IK• 142	IK• 148
115B-F-015	INS 172/10	10.0	IK• 121	IK• 122	IK• 128
115B-F-020	INS 172/16	16.0	IK• 141	IK• 142	IK• 148
115B-F-030	INS 172/25	25.0	IK• 161	IK• 162	IK• 168
115C-F-015	INS 172/16	16.0	IK• 141	IK• 142	IK• 148
115C-F-020	INS 172/25	25.0	IK• 161	IK• 162	IK• 168
115C-F-030	INS 172/25	25.0	IK• 161	IK• 162	IK• 168
115D-F-015	INS 172/16	16.0	IK• 141	IK• 142	IK• 148
115D-F-020	INS 172/25	25.0	IK• 161	IK• 162	IK• 168

1) for mounting matching connector: motor power connector

DB_KONFMOTLEIST

Figure 4.7: Ready-made motor power cables

Ordering guidelines

Example: IKL 001 / 12.0

Length in meters

L...standard cable with shield

F...flexible cable without shield

(not available in diameters 0.75
and 1.5 mm²)

G...cable with shield

(Available in increments of 0.5 meters after a length of five meters. Smaller lengths available upon request.)

5. Electrical motor feedback connection

5.1. Terminal diagram

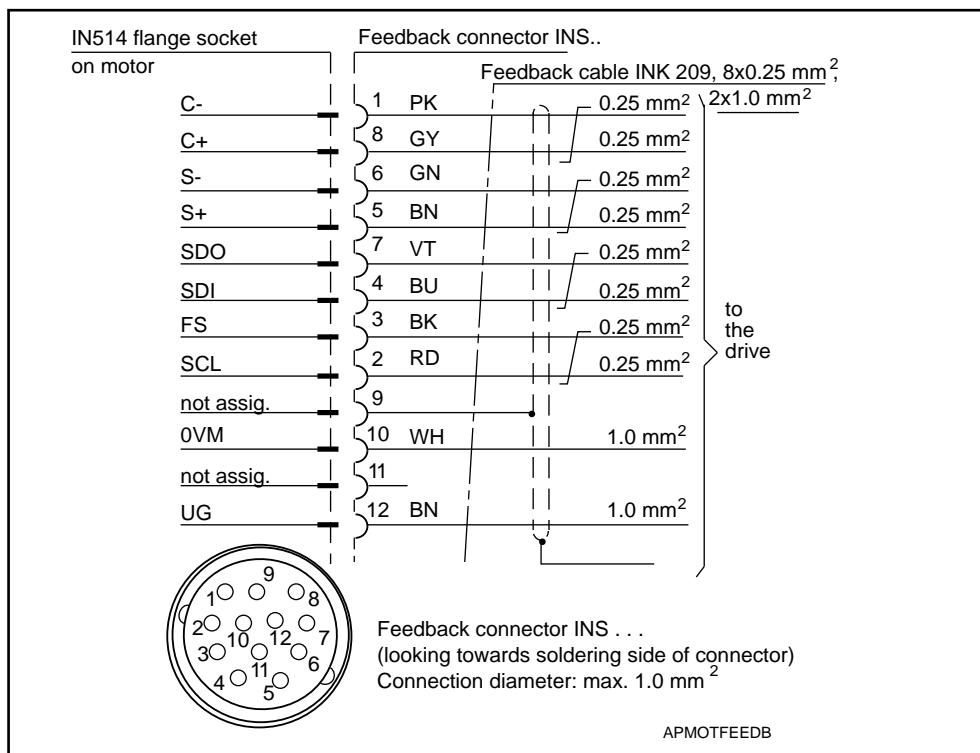


Figure 5.1: Terminal diagram



If own cables are used, then execute connecting cores per Figure 5.1. Improper execution could cause operational problems.

5.2. Feedback connector



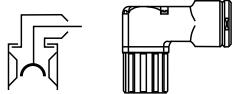

Designation	connectors for INDRAMAT cable INK 209	connectors for all cables with outside diameter of 6 to 10 mm
connector (straight)	INS 513 	INS 512 
connector (elbow)	INS 511 	INS 510 

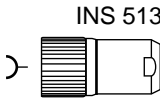
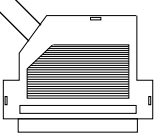
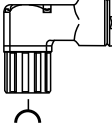
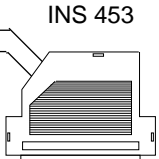
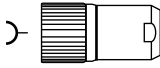
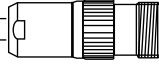
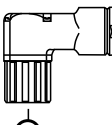


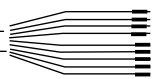
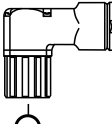
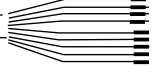
Figure 5.2: Feedback connector

5.3. Feedback cable - technical data

type designation	INK 209
cable-connector transition protection category	IP 65
cable diameter	8.8 mm
bending radius - fixed routing	40 mm
bending radius - flexible routing (lifespan greater than 500,000 bending loads)	90 mm
specific weight	0.102 kg/m
permissible ambient temperature for operating and storage	-30 °C to +80 °C
cable surface	does not adhere, prevents sticking in drag chains
maximum cable length	75 meters
chemical characteristics	absolute resistance to mineral oils and greases, hydrolysis resistant, silicone and halogen free

Figure 5.3: Technical data of feedback cable INK 209

5.4. Ready-made feedback cables

order designation for ready-made feedback cables	type designation for feedback connectors	INDRAMAT feedback cable	cable end
IKS 374 /...		INK 209	 <p>plug-in connector 15-pin D-subminiature connects to drive</p>
IKS 375 /...		INK 209	
IKS 376 /...		INK 209	
IKS 377 /...		INK 209	 <p>with coupling mounts to matching connector IN 513</p>
IKS 378 /...		INK 209	 <p>with ferrules to connect to terminal blocks ¹⁾</p>
IKS 379 /...		INK 209	

¹⁾ To be avoided as could interfere with shield.

Figure 5.4: Ready-made feedback cables

Ordering guidelines

Example: IKS 374 / 12.0

Length in meters

(Available in increments of 0.5 meters after five meter lengths. Shorter lengths available upon request.)

6. Coolant connections

The coolant connection can be executed as follows:

Connection type	Sketch			
hose nozzle	motor	hose nozzle	hose	hose clip
quick-coupler	motor	coupling with windings	coupling with threaded joint	hose
clamp connection	motor	clamp connection with windings	hose	

EKANSFL

Figure 6.1: Possible liquid-cooling connections

These parts cannot presently be obtained from INDRAMAT.

Coolant supply lines

The coolant supply systems can be made of either

- pipes, or,
- hoses.



There is a considerable degree of pressure loss in a pipe coolant supply system due to the re-routing points (e.g., 90° elbows) which unavoidably occur in such a system. We therefore recommend the use of a hose supply system.

When choosing a hose system, however, the pressure loss within the system must be taken into consideration. Thus, the inside diameter of the hose must equal at least 9mm and must narrow shortly before the point of connection to the motor in those cases where greater hose lengths are necessary.

Coolant The data listed in the documentation relates to water as coolant.

Further information on additives or other coolants are listed in the documentation, "Liquid coolant of INDRAMAT drive components".

Pressure drop A pressure drop under nominal conditions is given in the technical data. Should the flow of volume change

- because some other coolant is used, or,
- because regulating or adjusting devices are lacking,

then the pressure drop changes as depicted in the flow diagram.

Flow diagram

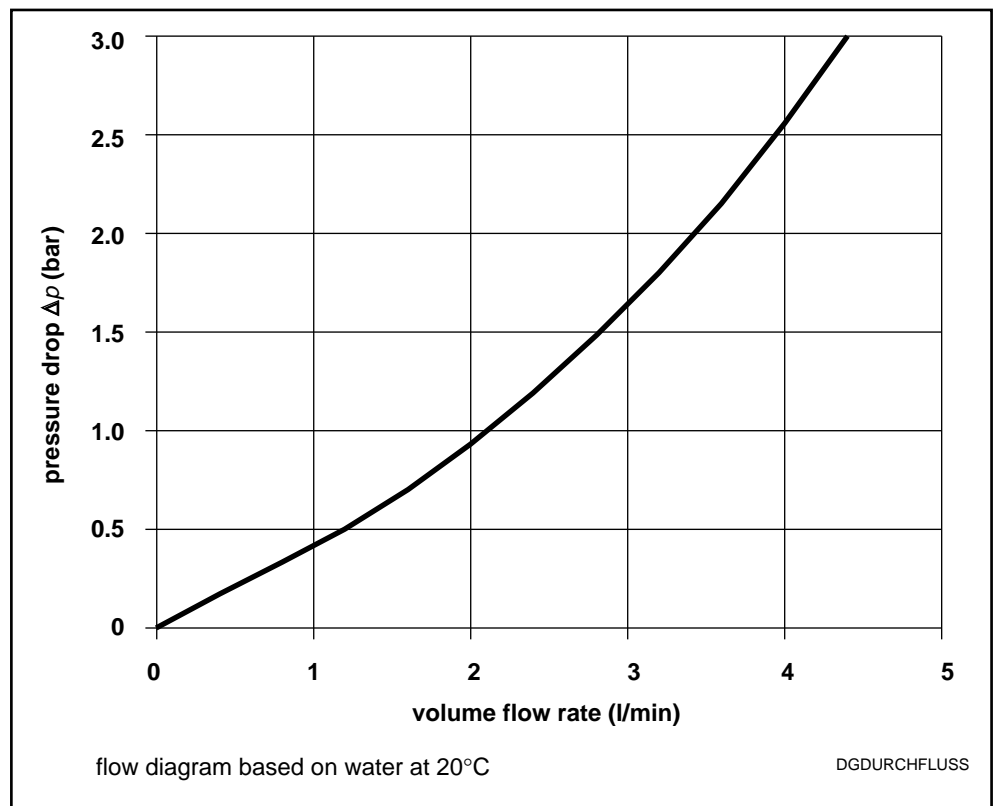


Figure 6.2: Flow diagram for an MDD servo motor

Supplementary information Supplementary information on cooling systems can be found in the documentation entitled: "Liquid cooling of INDRAMAT drive components".

7. Index

A

Ambient temperature 8
Application 15

B

Balance class 11

C

Centering diameters 10
Connector to cable allocation 68
Construction 6
Coolant 78
Coolant connections 77
Coolant supply lines 77

D

Digital servo feedback 9
Digital servo feedback with integrated multturn a 9
DSF 9
DSF+MTG 9

E

Elbow connector 13
Electrical motor feedback connection 74
Electrical power connections 67
Environmental conditions 8

F

Feedback cable 75
Feedback connector 12, 75
Flow diagram 78

H

High-dynamic applications 5
High-precision applications 5
Holding brake 11

I

Installation altitude 8

L

Labelling the sides 7

M

MDD 090 16
MDD 093 27
MDD 112 41
MDD 115 55
Motor feedback 6, 9
Motor power cables 71
Motor power connector 12
Motor power connectors 70
Mounting to the machine 7

MTG 9

O

Operating curves 14

Operating reliability 6

Output direction of the power connection 10

Output shaft 10

P

Performance data 6

Performance overview 5

Pressure drop 78

Protection category 8

R

Ready-made feedback cables 76

Ready-made motor power cables 72

S

Speed limiting values 14

T

Technical information 8

Terminal diagram 12, 67, 74

Torque limiting values 14

Torque-speed characteristics curves 14

